



## **City of Goshen Board of Public Works & Safety**

Regular Meeting Agenda

**4:00 p.m., JUNE 4, 2026**

Goshen Police & Court Building, 111 East Jefferson Street, Goshen, Indiana

**To access online streaming of the meeting, go to <https://goshen.in.gov/events/>**

### **Call to Order by Mayor Gina Leichty**

**Approval of Minutes:** May 28, 2026 Regular Meeting

### **Approval of Agenda**

**1) Police Department request:** Accept the retirement of Police Chief José Miller, effective June 12, 2026 with June 11, 2026 as his final day of active service

**2) St. John the Evangelist Catholic Church request:** Approve the use of City streets and sidewalks for the annual Corpus Christi Procession, noon to 1:30 p.m., on Sunday, June 7, 2026

**3) NIPSCO request:** Approve the closure of Firethorn Drive, at Hackberry Drive, on June 8, 2026 for a Distribution Automation (DA) project, which is part of a broader project in progress

**4) Legal Department request:** Approve and authorize Mayor Leichty to execute Amendment #1 to the contract with the Indiana Department of Transportation for Street Sweeping Services

**5) Environmental Resilience Department request:** Approve balancing Change Order No. 1 increasing the contract by \$822.72, for a final contract amount of \$105,365.97 for the 2026 Spring Tree Removal Project

**6) Engineering Department request:** Approve the closure of Chicago Avenue, from Pike Street to Indiana Avenue, from June 8, 2026, until July 2, 2026

### **Privilege of the Floor**

### **Approval of Civil City and Utility Claims**

### **Adjournment**



**CITY OF GOSHEN BOARD OF PUBLIC WORKS & SAFETY  
MINUTES OF THE MAY 28, 2026 MEETING**

*Convened in the Goshen Police & Court Building, 111 East Jefferson St., Goshen, Indiana*

**Present:** Mayor Gina Leichty, Mike Landis and Orv Myers

**Absent:** Mary Nichols and Barb Swartley

**CALL TO ORDER:** Mayor Leichty called the meeting to order at 4:00 p.m.

**REVIEW/APPROVE MINUTES:** Mayor Leichty presented the minutes of the May 14, 2026 and May 21, 2026 Regular Meetings. Board member Mike Landis made a motion to approve the minutes as presented. Board member Orv Myers seconded the motion. The motion passed 3-0.

**REVIEW/APPROVE AGENDA:** Mayor Leichty presented the agenda as prepared by the Clerk-Treasurer with the addition of agenda item #10, *Legal Department request: Approve and authorize Mayor Leichty to execute the agreement with Elevate Technology Partners to allow the City to enter into an agreement for On-Call Information Technology Services.* Board member Landis made a motion to approve the agenda as amended. Board member Myers seconded the motion. The motion passed 3-0.

**1) Police Department request: Approve the promotion of Officer Jared Ellison from the position of Probationary Patrol Officer to the rank of Patrol Officer, retroactive to May 12, 2026**

Interim Police Chief Andy Stephenson asked the Board to approve the promotion of Officer Jared Ellison from the position of Probationary Patrol Officer to the rank of Patrol Officer, retroactive to May 12, 2026.

Chief Stephenson said Officer Ellison successfully completed his 12-month probationary period on May 12, 2026. He added, "During this time, he has consistently demonstrated professionalism, reliability, and commitment to the values and mission of the Goshen Police Department. His performance has met or exceeded all expectations."

Landis/Myers made a motion to approve the promotion of Officer Jared Ellison from the position of Probationary Patrol Officer to the rank of Patrol Officer, retroactive to May 12, 2026. The motion passed 3-0. After the Board's approval, Mayor Leichty swore in Officer Ellison as a Goshen Patrol Officer.

**2) Police Department request: Approve the promotion of Officer Mitchell Garrett from the position of Probationary Patrol Officer to the rank of Patrol Officer, retroactive to May 12, 2026**

Interim Police Chief Andy Stephenson asked the Board to approve the promotion of Officer Mitchell Garrett from the position of Probationary Patrol Officer to the rank of Patrol Officer, retroactive to May 12, 2026.

Chief Stephenson said Officer Garrett successfully completed his 12-month probationary period on May 12, 2026. He added, "During this time, he has consistently demonstrated professionalism, reliability, and commitment to the values and mission of the Goshen Police Department. His performance has met or exceeded all expectations."

Landis/Myers made a motion to approve the promotion of Officer Mitchell Garrett from the position of Probationary Patrol Officer to the rank of Patrol Officer, retroactive to May 12, 2026. The motion passed 3-0. After the Board's approval, Mayor Leichty swore in Officer Garrett as a Goshen Patrol Officer.

**3) Police Department request: Accept the retirement of Captain Curtis Weldy from the Goshen Police Department, effective May 28, 2026**

Interim Police Chief Andy Stephenson asked the Board to accept the retirement of Captain Curtis Weldy from the Goshen Police Department, effective May 28, 2026. Captain Weldy's final day of active service was May 27, 2026.



**Chief Stephenson** said Captain Weldy began his policing career with the Goshen Police Department in 2013. Prior to joining the department, he served for nearly eight years with the Nappanee Police Department. Throughout the course of his career, **Chief Stephenson** said, "Captain Weldy has served as an instructor, sergeant, lieutenant, SWAT team leader, and training captain. More importantly, the chief said Cap/ Weldy "has been a friend and mentor to many. Captain Weldy holds many law enforcement certifications, and he has been the recipient of numerous awards and commendations, including the Goshen Police Department's Medal of Honor."

**Chief Stephenson** concluded, "Captain Weldy's service and commitment to our department, the Goshen community, and the policing profession as a whole are greatly appreciated. We thank Captain Weldy and wish him the best as he embarks on the next chapter in life. He will be missed."

**Mayor Leichty** agreed that Capt. Weldy would be missed and wished him the best.

**In his letter of retirement to the Chief, Mayor Leichty and the Board, Captain Weldy wrote as follows:**

"After a little over 20 years, it is time to start another adventure. While it hasn't always been easy, I am thankful I was granted the opportunity to have the experiences I have had, serve the citizens and gain the friendships of fellow officers. Additionally, I would like to emphasize my retirement is in no way related to the hiring of Chief Stephenson nor should it reflect any displeasure with Mayor Leichty's decision. I wish him and all the officers the best of luck and pray for their continued safety and success."

**Landis/Myers made a motion to accept the retirement of Captain Curtis Weldy from the Goshen Police Department, effective May 28, 2026. The motion passed 3-0.**

#### **4) Request from Mayor Leichty: Authorize the use of cooperative purchasing entities, including Sourcewell and other nationally recognized purchasing cooperatives, under the Indiana Code 5-22-10 governing special purchase methods**

**Mayor Leichty** requested the Board's authorization to use cooperative purchasing entities, including Sourcewell and other nationally recognized purchasing cooperatives, under Indiana Code 5-22-10 governing special purchase methods. She noted this new purchasing option should produce cost savings for the City.

#### **BACKGROUND:**

In a memorandum to the Board, **Mayor Leichty** wrote that the City has historically taken a cautious approach to cooperative purchasing, particularly with out-of-state entities, to ensure compliance with Indiana law and State Board of Accounts (SBOA) requirements. Based on further review, she wrote that with the development of a structured compliance process and SBOA counsel, the City is now positioned to use cooperative purchasing entities when they offer clear cost savings and are supported by appropriate documentation, legal review, and Board oversight. By way of background and rationale, **Mayor Leichty** wrote that the City anticipates several upcoming procurements of large equipment across departments. Research indicates that purchasing through co-op entities may offer substantial savings, potentially in the tens or hundreds of thousands of dollars.

**Mayor Leichty** wrote that she has reviewed the statutory framework and audit expectations with City Attorney Bodie Stegelmann and identified a compliant path using Indiana Code 5-22-10-5, which allows special purchases when a unique opportunity results in substantial savings. The City intends to use this authority, when appropriate, in a well-documented and transparent manner.

The **Mayor** wrote that the use of cooperative purchasing contracts, particularly those administered by out-of-state entities, requires careful alignment with Indiana statute. The City's proposed approach would establish a clear, legally defensible, and State Board of Accounts-compliant process that would allow the City to capture cost savings while maintaining transparency and accountability.

To ensure full adherence to Indiana law and State Board of Accounts guidance, the **Mayor** indicated that the City would follow a structured process as follows:



**1. Special Determination** – The requesting Department Head will submit a written Special Purchase Determination documenting the statutory basis and justification for the purchase.

**2. Pricing Analysis** – The requesting Department Head will develop a comparative pricing analysis demonstrating substantial savings or a unique opportunity.

**3. Legal Opinion** – The Legal Department will evaluate the request and provide a written opinion confirming compliance with Indiana purchasing requirements.

**4. Board Presentation** – The Legal Department will present the determination and supporting documentation to the Board of Public Works for approval and entry into the public record.

**5. Record Retention** – The Legal Department will maintain a complete procurement file and coordinate with the Clerk-Treasurer for official recordkeeping and audit purposes.

The **Mayor** wrote that City staff may request the purchase of goods through a cooperative purchasing entity where other Special purchasing methods may be available to the City, such as where an emergency exists (Indiana Code 5-22-10-4), where the compatibility of equipment, accessories, or replacement parts is a substantial consideration (Indiana Code 5-22-10-8), or where no responsive offer is received under another purchasing method (Indiana Code 5-22-10-10). These options will likely arise less frequently than unique opportunities to realize substantial savings; however, when such opportunities arise, the City will follow the process outlined above if any of these other methods are available.

**Mayor Leichty** wrote that this approach will ensure a transparent and legally defensible procurement process while allowing the City to take advantage of significant cost-saving opportunities. So, she asked the Board's approval to proceed under IC 5-22-10-5 and to incorporate cooperative purchasing into the City's procurement strategy.

**In her comments during the meeting, Mayor Leichty** said a cooperative purchasing agreement with an entity like Sourcewell, which is based in Minnesota, would "procure significant cost savings for the City, by buying through them, rather than just by issuing specifications and bidding through the City of Goshen. And in talking with fellow mayors throughout the State, they've found this can be a tremendous cost savings."

**Mayor Leichty** said the City Fire Chief and City Fleet Manager have explored this approach and believe it could produce cost savings of tens of thousands to hundreds of thousands in the purchase of a \$5 million fire truck.

The **Mayor** said utilizing a cooperative purchasing agreement requires a legal review process that any of those special requests would have to go through. She said this process would include a validation that the item being purchased is for a special purpose, "that significant savings are available and that any cooperative purchasing entity that we would utilize has gone through the proper bidding process that would be in accordance with the State of Indiana. She also said the City Attorney also would need to issue a statement that he reviewed that information and that it is in compliance with the State Board of Accounts and the legal process for the State of Indiana before it would come before the Board of Public Works & Safety for review and approval.

**After the Mayor's summary, City Attorney Bodie Stegelmann provided a further explanation.**

**Stegelmann** said that to use the cooperative purchasing arrangement, the City would need to show that it has a unique opportunity to experience substantial savings on a purchase. He said it could also be used when the compatibility of equipment was important or when no responsive bids were received.

In response to questions from **Board member Landis, Stegelmann** and the **Mayor** provided additional information and stressed the City would need to justify using a cooperative purchasing agreement. The Mayor said that Sourcewell would also seek bids for the City and has access to a broader network of suppliers. Stegelmann stressed that the City would need to closely scrutinize purchases using this approach.

**Mayor Leichty** said many cities and the State of Indiana are using Sourcewell. She added that so many municipalities are using Sourcewell that the State Board of Accounts issued a special memorandum about cooperative purchasing entities and made sure it outlined "potential pitfalls, as well as clarification on what municipalities need to do to avoid any audit (red) flags."



The **Mayor** added this request to the Board was the first step in using cooperative purchasing entities. **Landis/Myers made a motion to authorize the use of cooperative purchasing entities, including Sourcewell and other nationally recognized purchasing cooperatives, under the Indiana Code 5-22-10 governing special purchase methods. The motion passed 3-0.**

**5) Downtown Goshen Inc. request: Approve multiple street and parking space closures for several First Fridays throughout the year**

**Amanda Rose, Director of First Fridays for Eyedart Creative Studios**, requested multiple street and parking lot closures for several First Fridays throughout the rest of the year.

**Rose** said the biggest requested change was the request to close the intersection of Main and Jefferson streets on Aug. 7, from 9 a.m. to 11 p.m., for the Goshen Games cycling event.

In a memorandum to the Board, **Rose** wrote that parking space closure additions for June and July reflected the requests of the Elks Lodge. She clarified other street and parking lot closures on maps that were provided for each month through November.

**Rose** also noted that affected businesses have been notified of the closures. She requested street barricades for her requests and other City services.

In response to a question from the **Mayor**, a representative of the **City Street Department** said the requests were acceptable.

**Clerk-Treasurer Aguirre** expressed appreciation to Rose for timely communication and detailed requests to City staff. **Rose** responded, "Well, I appreciate all of you, so thank you."

**Landis/Myers made a motion to approve the request for multiple street and parking space closure for First Friday activities. The motion passed 3-0.**

**6) Parks & Recreation Department request: Approve the display of promotional banners on Main Street for upcoming community events during the summer months**

**Goshen Parks & Recreation Supervisor Kimberlee Stephen** requested approval to display promotional banners on Main Street for upcoming community events during the summer months.

**Stephens** requested a banner in June to promote "Kerry's Kids and Teen Mud Run" and a July banner to promote the "Rock the Quarry Adult Triathlon and Mile Swim."

**Stevens** said Premier Signs will be responsible for both the installation and removal of all banners in accordance with City guidelines and approved timelines. Proofs of the proposed banner designs were provided to the Board.

In response to a question from the Mayor, **Stephens** said these two events were taking place at the same time as last year.

**Landis/Myers made a motion to approve the display of promotional banners on Main Street for upcoming community events during the summer months. The motion passed 3-0.**

**7) Legal Department request: Approve the terms and conditions and ratify the execution of the Conditional Offer of Employment Agreement with Kael J. Hooley dated April 8, 2026**

**City Attorney Bodie Stegelmann** said a conditional offer of employment was extended on behalf of the Board to **Kael J. Hooley** for employment with the Goshen Fire Department, and a Conditional Offer of Employment Agreement was entered into on April 8, 2026.

**Stegelmann** recommended that the Board approve the terms and conditions and ratify the execution of the Conditional Offer of Employment Agreement.

**Landis/Myers made a motion to approve the terms and conditions and ratify the execution of the Conditional Offer of Employment Agreement with Kael J. Hooley dated April 8, 2026. The motion passed 3-0.**



**8) Legal Department request: Approve the Guaranteed Maximum Price Amendment No. 1 to the agreement with D-J Construction Co., Inc., as presented, and authorize Mayor Leichthy to execute the Amendment for the Goshen Annex Building project**

**Assistant City Attorney Don Shuler** told the Board the City and D-J Construction previously entered into an agreement dated Dec. 23, 2024 for renovation and improvements to the City Annex Building.

**Shuler** said the agreement contemplated the establishment of a Guaranteed Maximum Price (GMP) by amendment upon completion of pre-construction services. Following execution of the agreement, the City experienced funding constraints and elected to reduce the scope of the project to focus on critical building improvements.

**Shuler** said an attached GMP Amendment No. 1 established the GMP for the reduced project scope in the amount of \$750,000. The reduced scope consists principally of the installation of a new elevator (with associated demolition, structural framing, concrete, electrical), exterior masonry cleaning and tuckpointing, supply and installation of interior magnetic storm windows.

**Shuler** said substantial completion of the work is required within 120 days of the City's Notice to Proceed, and Payment and Performance Bonds are required. He confirmed to the **Mayor** that an elevator is included "with framing, concrete, electrical, all associated with it."

**Landis/Myers made a motion to approve the Guaranteed Maximum Price Amendment No. 1 to the Agreement with DJ Construction Co., Inc., as presented, and authorize Mayor Leichthy to execute the Amendment. The motion passed 3-0.**

**9) Legal Department request: Adopt Resolution 2026-09, City of Goshen Sidewalk Program, which would establish a framework for identifying public sidewalk needs and prioritizing public sidewalk improvements located within the public right-of-way, including providing funding assistance to property owners for the repair or replacement of eligible sidewalk segments**

**City Attorney Bodie Stegelmann** recommended that the Board approve Resolution 2026-09 for the City of Goshen Sidewalk Program.

**Stegelmann** said the Sidewalk Program establishes a framework for identifying public sidewalk needs and prioritizing public sidewalk improvements located within the public right-of-way, including providing funding assistance to property owners for the repair or replacement of eligible sidewalk segments.

**According to Resolution 2026-09:**

- The City Engineering Department maintains an inventory of public sidewalks, including public sidewalks located within the public right-of-way, documenting sidewalks in need of repair or replacement, and identifying areas where public sidewalks do not exist ("Sidewalk Inventory");
- The Sidewalk Inventory includes the Engineering Department's assessment of the condition of each public sidewalk segment and assigns a score to each segment based on the number and severity of defects;
- The City Engineering Department also receives public input concerning the condition of public sidewalks;
- The Sidewalk Inventory and public input are used to guide strategic and policy-driven decisions regarding the budgeting for and prioritization of public sidewalk improvements;
- The City annually allocates funding to be used for public sidewalk improvements; and
- The City of Goshen Sidewalk Program establishes a framework for identifying public sidewalk needs and prioritizing public sidewalk improvements located within the public right-of-way, including providing funding assistance to property owners for the repair or replacement of eligible sidewalk segments.

**If approved by the Board, establish: the criteria for the need for, and prioritization of, the installation, repair, or replacement of public sidewalks; the Sidewalk Funding Assistant Program; ADA compliance; and a required annual summary "identifying public sidewalk locations installed, repaired, or replaced, together with the associated costs incurred under the Sidewalk Program."**



This annual summary will be used to evaluate the effectiveness of the Sidewalk Program, support future budgetary and policy decisions, and promote transparency and accountability in the expenditure of public funds.

**Landis/Myers made a motion to adopt Resolution 2026-09, City of Goshen Sidewalk Program. The motion passed 3-0.**

**10) Technology Department request: Approve and authorize Mayor Leichty to execute the agreement with Elevate Technology Partners to allow the City to enter into an agreement for On-Call Information Technology Services**

**City Director of Innovation and Technology Mattie Lehman** presented an agreement for expert technical advising and services with Elevate Technology Partners. Lehman said the total possible cost is a not-to-exceed total of \$29,250, which will equate to 130 hours of service.

**Lehman** said if all 130 hours that are allowed by this agreement are used, this agreement will be deemed complete and a new agreement will be negotiated should the City decide to continue working with this contractor.

There is no expiration date for this agreement. However, **Lehman** said if any of the events in the agreement that would trigger termination of the agreement occur, the terms of the agreement shall be in full force and effect.

**Lehman** said Elevate's work will include a resiliency project to boost City's network. She added, "We've gone down a couple of times this spring, so this is a high priority project. I've spent a lot of time interviewing companies since I started this position last fall, and I think the scope and expertise of Elevate best fits our current needs and comes highly recommended by a few other regional communities."

In response to a question from **Board member Landis**, Lehman said she expects the company will conclude its work by the end of the year.

Under a scope of services, Elevate Technology Partners Contractor will provide City the services including but not limited to on-call consulting services regarding the network, voice server, storage, virtualization data, AI readiness and Microsoft.

**Landis/Myers made a motion to approve and authorize Mayor Leichty to execute the agreement with Elevate Technology Partners to allow the City to enter into an agreement for On-Call Information Technology Services. The motion passed 3-0.**

**NOTE:** For this added agenda item, City Paralegal Christina Bonham presented the Board with a one-page memorandum, dated May 28, 2026, and an 8-page agreement with Elevate Technology Partners (**EXHIBIT #1**).

**11) Engineering Department request: Approve Change Order No. 7 in the amount of \$88,130 and an additional seven days, to provide underground drainage, for the Steury Avenue and Lincoln Avenue Reconstruction and Drainage Improvements**

**City Director of Public Works & Utilities Dustin Sailor** told the Board that Niblock Excavating has consistently encountered pockets of trapped groundwater flowing within existing utility trenches in Phase 11 of this project. In order to intercept and drain groundwater away from the proposed roadway subbase, Sailor said City staff and Niblock believe that additional underground drainage is necessary.

**Sailor** said this consists of additional 6-inch perforated PVC pipes at the intersection of Lincoln Avenue and Steury Avenue, as well as field-perforating the proposed 12-inch PVC storm pipes in locations where these cross the roadway. Perforated pipes will be encased in clean No. 8 aggregate, lined with geotextile. Tracer wire would be run with the 6-inch perforated pipes to aid location.

Niblock Excavating provided linear foot prices of \$149 for the 6-inch pipes and \$159 for the 12-inch pipes, each including all labor and materials. The 6-inch price is comparable to the cost for similar underground drainage installed during the City's recent reconstruction of Hackett Road. Niblock has requested seven (7) days to be added to the contract to complete this work.



**Sailor** asked that the Board approve Change Order No. 7 for \$88,130. This change, along with previous changes, increases the value of the contract by 3.26%. Goshen Redevelopment approved Change Order No. 7 at the May 12, 2026, Redevelopment Commission meeting.

**Landis/Myers made a motion to approve Change Order No. 7 in the amount of \$88,130.00 and an additional seven days, to provide underground drainage. The motion passed 3-0.**

**12) Engineering Department request: Approve the balancing Change Order No. 3 by reducing the contract by \$306,716.22, for a final contract amount of \$4,348,010.79 for the Asphalt Paving Project**

**City Director of Public Works & Utilities Dustin Sailor** provided the Board with Change Order No. 3 - A Balancing Change Order for the 2026 the Asphalt Paving Project.

**Sailor** said the change order would reduce the amended contract price by \$306,716.22 making the final contract amount \$4,348,010.79. This amount is 4.79% under the contract amount of \$4,654,727.00 due to the previous change orders.

<b>Contract amount as previously amended:</b>	<b>\$4,654,727.00</b>
<b>Change Order No. 3:</b>	<b>\$ -306,716.22</b>
<b>Revised contract amount:</b>	<b>\$4,348,010.79</b>

**Landis/Myers made a motion to approve the balancing Change Order No. 3 by reducing the contract by \$306,716.22, for a final contract amount of \$4,348,010.79. The motion passed 3-0.**

**13) Engineering Department request: Permit Maple Indian, 127 South Main Street, to install outdoor seating as detailed and in accordance with the requirements contained in the Temporary Outdoor Seating in Public Right-of-way application through Oct. 30, 2026**

**City Civil Engineer Brad Minnick** told the Board that Maple Indian, 127 South Main Street, has provided a sufficient Temporary Outdoor Seating in the Public Right-of-way application for 2026.

Goshen Engineering recommended approval of the Maple Indian's Outdoor Seating in the Public Right-of-way application through Oct. 30, 2026.

**Rosie Morales Singh**, the owner of Maple Indian, asked if a new application will need to be completed next year.

**Mayor Leichty** responded that a new application must be filed every year for outdoor seating but added that the City "will try to make it as painless as possible."

**Landis/Myers made a motion to permit Maple Indian to install outdoor seating as detailed and in accordance with the requirements contained in the Temporary Outdoor Seating in Public Right-of-way application through Oct. 30, 2026. The motion passed 3-0.**

**14) Engineering Department request: Approve the closure of the sidewalk and four parking spaces on the south side of the Abogado Law Firm office, at Main Street and Lincoln Avenue, for a vault closure**

**City Director of Public Works & Utilities Dustin Sailor** told the Board that Yaw Construction has begun working on closing the vault at the Abogado Law Firm office, 102 North Main Street.

He requested retroactive approval for four parking spaces to be closed – four on the south side of the building to accommodate dump trailers and trucks. The sidewalk on the south side of the building also has been closed for the safety of pedestrians. The closure will be in effect until June 4.

**Landis/Myers made a motion to approve the closure of sidewalk and four parking spaces on the south side of the Abogado Law Firm office for the vault closure. The motion passed 3-0.**

**15) Engineering Department request: Approve the Annual Operational Report and authorize the Mayor to sign the certification**



**City Civil Engineer Brad Minnick** told the Board the City of Goshen is required to submit an Annual Operational Report for Local Roads and Streets and Bridges to the State Board of Accounts (SBOA) by June 1 following the operational report year through the Local Technical Assistance Program (LTAP) at Purdue University.

**Minnick** said a completed Annual Operational Report prepared by the Clerk-Treasurer's Office and Street Department is attached. The final page of the report is a certification required to be signed by the City Engineer, the Street Commissioner, and the Mayor.

**Minnick** asked the Board to approve the Annual Operational Report and authorize the Mayor to sign the certification.

**Clerk-Treasurer Aguirre** said, "This really is a team effort involving a lot of people, but I think it's important to acknowledge the extraordinary contributions of Kendra Collat, the City Asset Manager, for the Department of Innovation and Technology. She kept everybody moving forward ... and it's a very complete report."

**Landis/Myers made a motion to approve the Annual Operational Report and authorize the Mayor to sign the certification. The motion passed 3-0.**

**Privilege of the Floor (opportunity for public comment for matters not on the agenda):**

**Mayor Leichty opened Privilege of the Floor at 4:38 p.m. There were no comments.**

**ADJOURNMENT**

**Mayor Leichty made a motion to approve Civil City and Utility claims and adjourn the meeting. Board member Myers seconded the motion. The motion passed 4-0.**

**ADJOURNMENT**

**Mayor Leichty adjourned the meeting at 4:39 p.m.**

**EXHIBIT #1:** *City Paralegal Christina Bonham presented the Board with a one-page memorandum, dated May 28, 2026, and an 8-page agreement with Elevate Technology Partners LLC for added agenda item #10, Technology Department request: Approve and authorize Mayor Leichty to execute the agreement with Elevate Technology Partners to allow the City to enter into an agreement for On-Call Information Technology Services.*

**APPROVED:**

---

**Mayor Gina Leichty**



---

**Mike Landis, Member**

---

**Orv Myers, Member**

---

**Mary Nichols, Member**

---

**Barb Swartley, Member**

**ATTEST:**

---

**Richard R. Aguirre, Clerk-Treasurer**



Andy Stephenson  
Interim Chief of Police  
Goshen Police Dept.  
111 E. Jefferson St.  
Goshen, Indiana 46528

TO: Goshen Board of Public Works & Safety  
Mayor Gina Leichty  
Member Mike Landis  
Member Mary Nichols  
Member Barb Swartley  
Member Orv Myers

Date: June 4, 2026

From: Andy Stephenson, Interim Chief of Police

Reference: The Retirement of Chief Jose Miller

I respectfully request that the Board of Public Works and Safety accept the retirement of Chief Jose Miller from the Goshen Police Department, effective June 12, 2026. Chief Miller's final day of active service will be June 11, 2026.

Chief Miller has served the Goshen community with dignity and a passion for service for more than 30 years. He began his policing career with the Goshen Police Department in 1995 and progressed through various roles and ranks, including detective, motorcycle officer, drug unit officer, SWAT team commander, and assistant chief. He was named the 22<sup>nd</sup> police chief of the Goshen Police Department in 2018.

Quoting Chief Miller, "...*Serving this department and this community has been the honor of a lifetime. During my tenure, we've faced difficult challenges and celebrated hard-earned victories. I'm proud of the men and women who I serve alongside—officers who show up every day with courage, professionalism, and an unwavering sense of duty. Together, we've worked to strengthen public trust, reduce crime, and build a department that respects both tradition and accountability. To the citizens of Goshen, thank you for your support, your expectations, and your partnership. And to the Mayor and City Council, I am grateful for the trust you placed in me and the support you have shown to the department. Though I may be retiring from the badge, I will always remain committed to the well-being and safety of this city.*"

Chief Miller's service and commitment to our department, the residents of Goshen, and the policing profession are greatly appreciated. We thank Chief Miller for his leadership, and we wish him the best as he begins a new adventure. He will be missed.

Respectfully,

Andy Stephenson  
Interim Chief of Police



**Jose' D. Miller**

**Chief of Police**

111 E Jefferson St  
Goshen, Indiana 46528

November 26, 2025

**The Honorable Gina Leichty**

Office of the Mayor  
Goshen, Indiana 46528

Dear Mayor Leichty, Members of the City Council, and Citizens of Goshen,

I am formally announcing my intention to retire as Chief of Police, effective June 12, 2026. By that date, I will have served the City of Goshen for more than 30 ½ years.

This decision did not come lightly. Serving this department and this community has been the honor of a lifetime. I have always believed in leading with integrity, standing firm on what's right, and upholding the trust that the badge represents—not for personal gain, but for the good of the city as a whole.

During my tenure, we've faced difficult challenges and celebrated hard-earned victories. I'm proud of the men and women who I serve alongside—officers who show up every day with courage, professionalism, and an unwavering sense of duty. Together, we've worked to strengthen public trust, reduce crime, and build a department that respects both tradition and accountability.

While it is time for me to step aside, I do so with confidence in the future of this department and the leadership that will follow. The values that shaped this city—duty, respect, service—must remain at the heart of everything we do.

To the citizens of Goshen, thank you for your support, your expectations, and your partnership. And to the Mayor and City Council, I am grateful for the trust you placed in me and the support you have shown to the department.

Though I may be retiring from the badge, I will always remain committed to the well-being and safety of this city.

With respect and gratitude,

**Jose' D. Miller #116**

Chief of Police  
Goshen City Police Department



# St. John the Evangelist Catholic Church

422 South Main Street • Goshen, IN 46526 • 574.533.3385

June 1, 2026

City of Goshen  
Board of Public Works and Safety  
Goshen, IN 46526

Dear Members of the Goshen Board of Public Works and Safety:

St. John the Evangelist Catholic Church respectfully submits for your review the following request.

St. John's is planning to have the annual Corpus Christi Procession on Sunday, June 7, 2026. From 12pm to 1:30pm. This event allows our parishioners to come together for worship and fellowship, which brings spiritual growth and goodness. I have provided a map with arrows showing our planed route.

The Corpus Christi procession will begin inside the church and will be exiting through the main door (Main St.), the procession will take a slight right turn to be on Monroe St. until we get to the intercession of South 3<sup>rd</sup> St. and Monroe. Here, we will need barricades to stop traffic for our parishioners to cross towards River Race Dr. Once the parishioners cross, we will go straight to the street adjacent to River Race Dr.; we will go around and then be on Rive Race Dr. again, we will process on River Race Dr. until we come to the stop sign by the Hawks. Then the procession will take a right on W. Madison St. We will need barricades at the intersection of the W. Madison St. and South 3<sup>rd</sup> street. The procession will then enter the north parking lot and take a slight right into the alley, which will lead us back to the church.

In the map, I have included the route with arrows where parishioners will process, and indicated where we need barricades to stop traffic. Traffic will stop for about 10 minutes at each intersection.

Last year the board approved the route requested above.

Thank you for your time and consideration.

Sincerely,

Jonathan Evangelista Rios  
Pastoral Associate

AQI 35

Hawks Art and Enterprise Center



W. Madison St.

Barricades

North Parking Lot

Chase Bank



River Race Dr.

Barricades

Alley

S MAIN ST

St. John the Evangelist Catholic Church



Barricades

Monroe St.

Barricades

E MONROE

S THIRD ST

Parked Car



S MAIN ST

RIVER RACE DR

W PURL ST



**Richard Aguirre, City Clerk-Treasurer**  
**CITY OF GOSHEN**

202 South Fifth Street, Suite 2 • Goshen, IN 46528-3714

Phone (574) 533-8625 • Fax (574) 533-9740

[richardaguirre@goshencity.com](mailto:richardaguirre@goshencity.com) • [www.goshenindiana.org](http://www.goshenindiana.org)

TO: Board of Public Works & Safety  
FROM: Clerk-Treasurer Richard R. Aguirre  
RE: NIPSCO request for road closure  
DATE: June 4, 2026

---

**The Clerk-Treasurer's Office received the following request from NIPSCO:**

Attached is a requested road closure date for an upcoming NIPSCO Distribution Automation (DA) project. Attached are the traffic plan, design drawing, and approved permit. Please let me know if you need anything further to have this presented on the June 4th BOW meeting.

**Area 4 - City of Goshen (Firethorn Drive at Hackberry Drive)**

**Replace Pole 1062096: 6/08/2026**

**Replace 3-300 KVAR CAP: 6/08/2026**

In March, the Board approved NIPSCO's request for lane restrictions and street closures on collector and arterial roadways – pursuant to a Right-of-Way Permit issued by the City Engineering Department – to replace five utility poles and related equipment, including conductors and wires. The traffic control included full road closures for AREAS 9 (113 East Lincoln Avenue), 12 (202 South 5th Street), 13 (308 East Douglas Street) and 14 (309 East Monroe Street). Traffic control also includes single lane closures for AREAS 3 (1802 East Lincoln Avenue), 5 (202 Blackport Drive), & 11 (416 Steury Avenue). Regarding the timing of these projects, all of this work was scheduled during April 2026, with lane restrictions or closures only in effect from 7 a.m. to 5 p.m. on the days of work indicated, weather permitting.

**Salena Pena**

Permit Specialist, NIPSCO

801 E 86th Ave., Merrillville, IN 46410

(M) 219.433.9412 | [spena@nisource.com](mailto:spena@nisource.com)



**ENGINEERING DEPARTMENT  
CITY OF GOSHEN**

204 East Jefferson Street, Suite 1 • Goshen, IN 46528-3405  
Phone (574) 534-2201 • Fax (574) 533-8626  
engineering@goshencity.com • www.goshenindiana.org

## Right-of-Way Permit

**Permit #:** 20252139-ROW      **Permit Type:** Right-of-Way / Excavation / Utility  
**Date Applied:** 12/2/2025      **Date Issued:** 1/6/2026  
**Applicant:** NIPSCO  
801 E 86th Ave, Merrillville, IN 46410  
(219) 433-9412, spena@nisource.com

**Project Address:** 2429 Lincolnway E, Firethorn Dr      **Contractor:** NIPSCO  
**Lot #:**      **Information:** 801 E 86th Ave  
**Use Zone:** M-1      Merrillville, IN 46410  
**Work Type:** NIPSCO - WO# 4000047853: Replace two (2) utility poles including the overhead equipment and transfer of conductors/wires to the new poles. Traffic control to consist a full road closure for AREA 4. Traffic control to consist of a single lane closure for AREA 3.

<u>Street Cut Surface</u>	<u>Dimensions (ft)</u>	<u>Quantity</u>
Sod	3 x 3	2

### Conditions

This permit is contingent upon the information provided, and the applicant hereby agrees to the terms outlined below under 'Right-of-Way Terms,' as well as any special conditions specified herein:

- Goshen Engineering is to be notified of the start date prior to initiating work.
- Permit drawing(s) provide additional comments to be included as part of the permit conditions.
- Utility is responsible for ensuring all company-owned and abandoned utility poles are removed regardless of whether subordinate utilities are on the pole.
- Utility shall obtain utility locates and maintain: 5' buried horizontal separation to public water main; 10' buried horizontal separation to sanitary and storm sewer; a minimum of 10' (preferably 15') separation from utility poles and public water or sewer lines; 18" buried vertical separation to water & sewer assets.
- Utility pole offset to the face of curb to be 1.5' (0.5m) minimum. When no curb exists, pole offset shall be 5' (1.5 m).
- Disturbed lawn areas within a utility easement or right-of-way shall be restored with INDOT Type U seed and then stabilized with an erosion control blanket.
- Firethorn Road closure to be coordinated with Goshen Engineering. Road is schedule for reconstruction in 2026.
- Lane restrictions and street closures require approval from Board of Works and Safety. The request is to be sent to the City of Goshen Engineering by Monday prior to the Thursday Board of Works and Safety meeting at 4:00 p.m. Meetings are held on the 1<sup>st</sup>, 2<sup>nd</sup>, and 4<sup>th</sup> Thursday of the month.

Approved for Issuance:

  
Dustin K. Sailer  
Director of Public Works

**Amount Due:** \$20.00  
**Amount Paid:** \$20.00  
**Payment Type:** Check - 5059087833  
**Payment Date:** 1/6/2026

**The applicant must schedule a final inspection by contacting Goshen Engineering at (574) 534-2201 or by scheduling online.**

## Right-of-Way Permit Terms

The Permittee and/or all Contractors Shall:

1. All work requiring a Right-of-Way Cut Permit must be performed in accordance with the terms of this permit, the Construction Standard Details (here), and Goshen Ordinance No. 3659.
2. Work is permitted only between the hours of 7:00am to 8:00pm. No work shall be conducted outside of these designated hours.
3. The Street Commissioner, Engineering Department, or their authorized representative reserves the right to stop work at any time.
4. Permits are valid for a period of three (3) months from the date of issuance, unless an extension is granted by the Engineering Department. If work is not completed within this time frame, a new permit must be obtained.
5. If any road or sidewalk closures or restrictions are required, a traffic control plan must be submitted for review and approval by the Board of Public Works and Safety. For meeting schedules and details, please contact Goshen Engineering at 574-534-2201.
6. Within areas affecting vehicular and pedestrian traffic, install and maintain appropriate warning signs, barricades, and warning lights in accordance with the Manual on Uniform Traffic Control Devices for Construction and Maintenance Areas. Any traffic disruption requires approval from the Board of Public Works and Safety (see Term No. 5). Permit holders must also notify 911 immediately when any street is closed to emergency vehicles.
7. Any structures installed under this permit must be moved or removed at the permit holder's expense if future traffic conditions or road improvements necessitate.
8. Permit holders shall not interfere with any existing structure along or across a city street without the express permission of the structure's owner.
9. Boring under pavement is required unless deemed impractical. If a pavement cut is necessary, it must be initiated with a saw cut to a minimum depth of three inches. The cut must be at least one foot wider on each side than the trench to be excavated.
10. All pipes, conduits, and materials used must meet the specifications of the City of Goshen with respect to size and quality.
11. Backfill around pipes, conduits, and trenches must be compacted in four-inch layers using thorough tamping to ensure high compaction. Under pavement - flowable fill shall be used above the granular pipe embedment unless in water or otherwise authorized. In such cases, a granular (no organic) material may be used, and compaction must be inspected by the City prior to final pavement restoration. Other areas - Excavated material may be reused as backfill. Temporary pavement surfaces - Must consist of a minimum of six inches of crushed limestone, maintained smooth and uniform until final resurfacing, which must occur within four (4) weeks.
12. Any removed pavement, driveway, or sidewalk must be replaced with materials of equal or better quality and restored to the original condition. Sod must be restored through replacement or proper seeding.
13. Permit holders are responsible for repairing any settling that occurs within one year of project completion.
14. The permit holder/sub-contractors assume all responsibility for any injury or damage to persons or property resulting directly or indirectly from the permitted work. Pavement restoration must be completed by a contractor approved by the City. Contractors remain on the City's approved list based on performance, compliance, and proper equipment use.

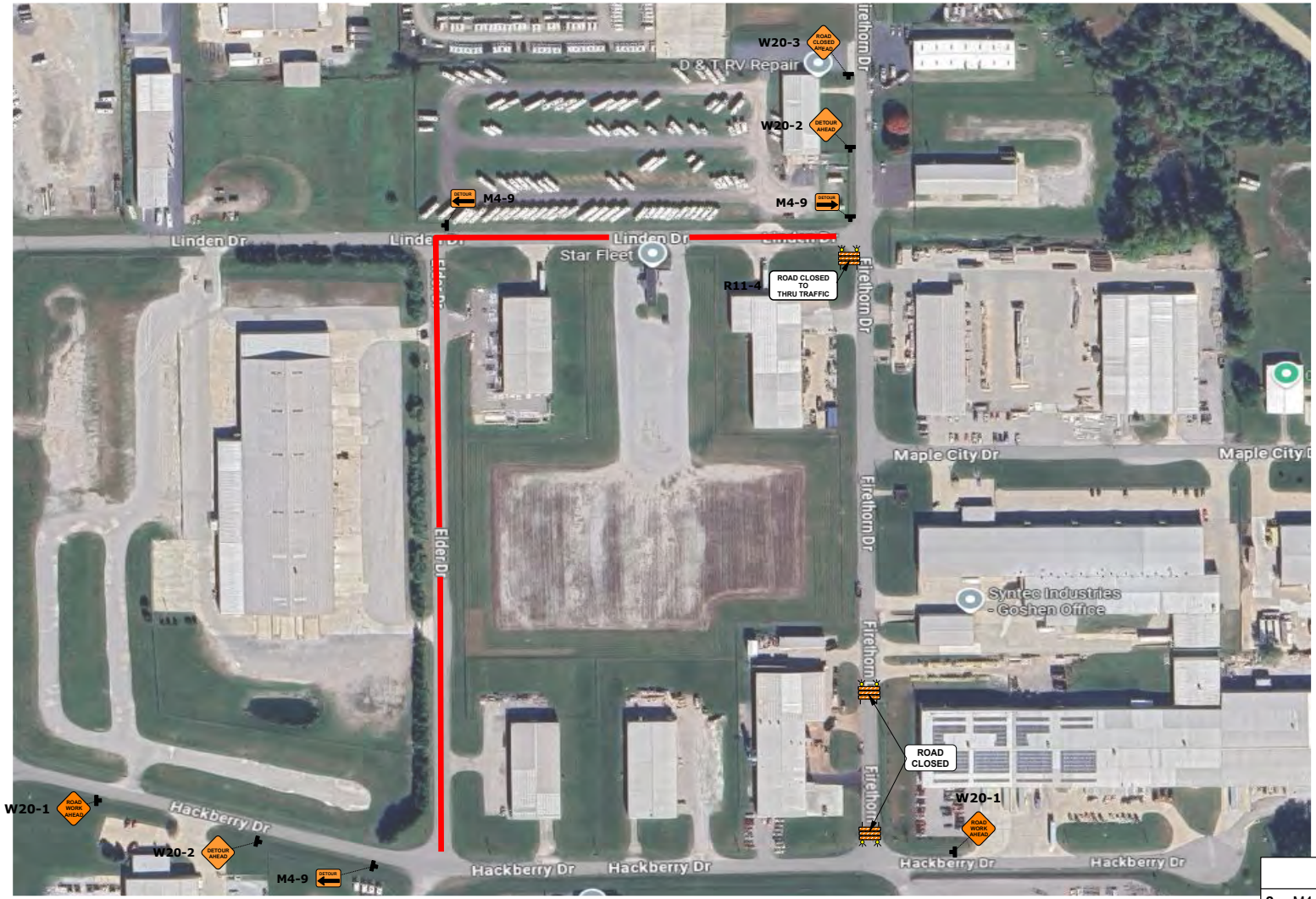

Manifest	
2 x	M4-9 detour (L)
2 x	W20-1 road work ahead
2 x	W20-2 detour ahead
1 x	M4-9 detour (R)
1 x	R11-2 road closed R11-2
1 x	R11-4 road closed to thru traffic
1 x	W20-3 road closed ahead

Date: 8/29/2024 Author: HighStar Traffic Project: Brown St - Portage, IN - Closure/Detour  
 Prepared for: Nipsco Sheet: 1 of 1 Scale: N.T.S.

Comments:  
 Plan provided to meet MUTCD standards, any additional requirements may need to be approved. Plans are non signed, sealed, and are for illustration to governing agency for approval. ▲



# TDSIC-OTHER-OEI-VIPER RECLOSERS 2024-HORN DITCH 1267, 1269, & 12-797, GOSHEN

## GOSHEN LOA PACKET 5

### PROJECT DESCRIPTION

#### INSTALL:

- (4) 45'-3 POLES, (1) 50'-3 POLE
- (3) 3-200 KVAR CAPACITOR BANKS
- (1) 333 KVA REGULATOR BANK

#### RETIRE:

- (1) 50'-3 POLE, (2) 40'-4 POLES
- (2) 3-300 KVAR CAPACITOR BANKS
- (1) 3-200 KVAR CAPACITOR BANKS
- 62' OF 3 PHASE 12.5 KV 336 ACSR
- 62' OF NEUTRAL 2/0 AA

#### REFRAME:

- (2) POLES

### GENERAL INFO

- 1) 138KV CIRCUIT 138103 CLEARANCE IS REQUIRED (SH.3)
- 2) ALL EXCESS SOILS ARE TO BE TREATED AS CONTAMINATED AND PROPERLY REMOVED AND DISPOSED OF
- 3) TRANSFER ALL CONDUCTORS TO NEW POLE
- 4) TRAFFIC CONTROL NEEDED
- 5) BACKFILL POLE WITH GRAVEL
- 6) ALL PHASING DOWNSTREAM OF TAP PHASE CHANGES TO BE UPDATED BY MAPS & RECORDS.
- 7) ALL GAS LINES SHOWN ARE FOR REFERENCE USE ONLY AND SHALL ONLY BE USED AS A SUPPLEMENTARY TOOL TO ASSIST DURING CONSTRUCTION. THOSE PERFORMING EXCAVATION WORK SHALL BE RESPONSIBLE FOR ENSURING PROPER LOCATES ARE COMPLETED.
- 8) PFR #NI-23-129
- 9) PRIOR TO DIGGING, LOCATE ALL EXISTING UTILITIES
- 10) INSTALLATION SHALL CONFORM TO NIPSCO SPECIFICATIONS AND STANDARDS

POTENTIAL SAFETY ISSUES AT JOB SITE	
<input type="checkbox"/>	CHILDREN AT PLAY (SCHOOL / PARK AREA)
<input checked="" type="checkbox"/>	RESIDENTIAL AREA
<input type="checkbox"/>	HIGH PEDESTRIAN TRAFFIC
<input checked="" type="checkbox"/>	HIGH VEHICULAR TRAFFIC
<input type="checkbox"/>	UNEVEN TERRAIN
<input checked="" type="checkbox"/>	LIMITED SPACE FOR VEHICLE PARKING/MANEUVERING
<input checked="" type="checkbox"/>	BURIED ELECTRIC/GAS IN VICINITY
<input type="checkbox"/>	OTHER: _____

### SHEET INDEX

Sheet	Description
1	COVER SHEET
2	CIRCUIT DIAGRAM
3-5	PLAN VIEW SHEETS
6	POLE DETAILS

PERMIT INFORMATION	
TOWN-	GOSHEN
COUNTY-	ELKHART
RAILROAD-	NONE
INDOT-	NONE
ENVIRONMENTAL-	SITE SPECIFIC

Electric System Data	
CIRCUIT #(S):	138103
SUBSTATION:	GOSHEN JUNCTION 80

Electric System Data	
CIRCUIT #(S):	12-797, 1267, 1269, 1255
SUBSTATION:	HORN DITCH 311

### VICINITY MAP

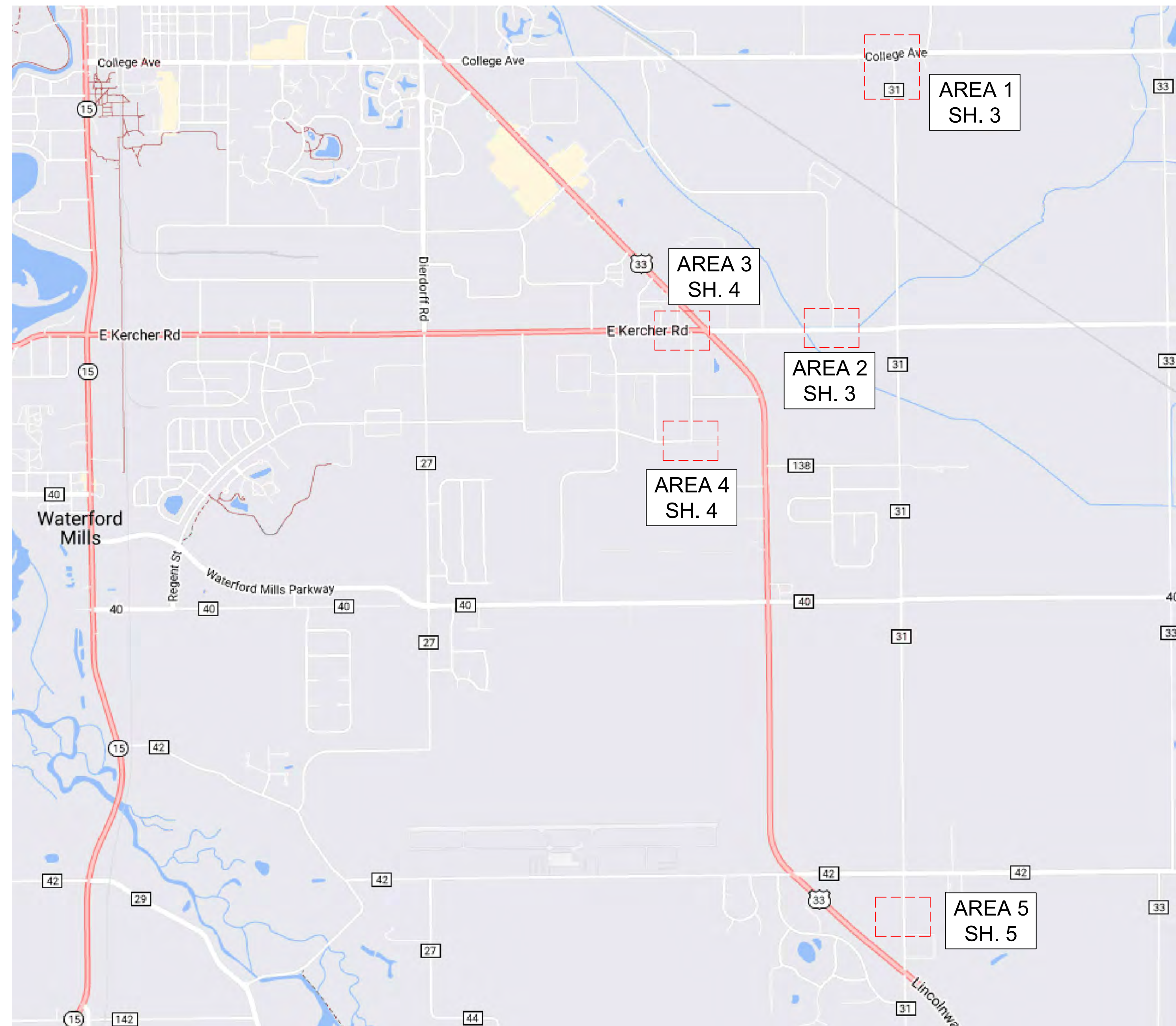

### LEGEND

	EXIST / PROP 10 OVH
	EXIST / PROP 20 OVH
	EXIST / PROP 30 OVH
	EXIST / PROP 69 KV
	EXIST / PROP SECONDARY
	EXIST / PROP 10 URG
	EXIST / PROP 20 URG
	EXIST / PROP 30 URG
	EXISTING GAS LINE
	CABLE TERMINATION
	CAPACITOR
	FUSE SINGLE SHOT
	FUSE SOLID BLADE
	FUSE TRIPLE SHOT
	GUY DOWN EXISTING
	GUY DOWN PROPOSED
	GUY EXISTING ADDITIONAL
	GUY PROPOSED ADDITIONAL
	OPEN POINT
	PROPOSED POLE
	CUSTOMER OWNED POLE
	NIPSCO OWNED POLE
	FOREIGN OWNED POLE
	RETIREMENT SYMBOL
	PRIMARY METERING PADMOUNT
	PRIMARY METERING POLE MOUNT
	PRIMARY PEDESTAL
	RECLOSER
	REGULATOR
	SECONDARY PEDESTAL
	SECTIONALIZER
	STREET LIGHT
	SWITCH N.C. GROUND OPERATED
	SWITCH N.C. HOOK OPERATED
	SWITCH N.C. DISTRIBUTION AUTO
	SWITCH N.O. GROUND OPERATED
	SWITCH N.O. HOOK OPERATED
	SWITCH N.O. DISTRIBUTION AUTO
	XFRM POLE 10
	XFRM POLE 20 BANK
	XFRM POLE 30 BANK
	XFRM PADMOUNT

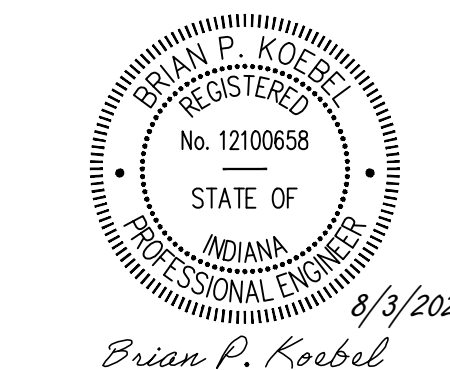

**ISSUED FOR CONSTRUCTION**

CONTRACT SERVICES	DESCRIPTION	PREPARED	REVIEWED	APPROVED	DATE
3	ISSUED FOR CONSTRUCTION	MAP	TJB	BK	08/3/23
2	ISSUED FOR REVIEW 90%	MAP	JDD	BK	07/14/23
1	ISSUED FOR REVIEW 30%	MAP	FP	BK	03/13/23

PROJECT: HAM.22.8648

**AS BUILT**  
ID#: \_\_\_\_\_ DATE: \_\_\_\_\_  
SIGN: \_\_\_\_\_  
COMPANY: \_\_\_\_\_

Revision
3: IFC



DRAWN: M. PETERS	SCALE: NTS	ENGR.: M. PETERS	TOWNSHIP: VARIOUS
E-MAIL: MPETERS@ORBITALENGR.COM		OFFICE: (219) 989-3300	TDSIC-OTHER-OEI-VIPER RECLOSERS 2024 HORN DITCH
DATE: 08/03/2023		CELL: (219) 699-8075	1267, 1269, & 12-797, GOSHEN GOSHEN LOA PACKET 5
APPROVED: BPK		TAXING UNIT: G12, G15, G20	LOCATION: GOSHEN, IN
			COUNTY: ELKHART
			WO#: 52991-912
			M#: M9868469
			R.WO#: 82991-912
			SHEET: 1 of 6



# TDSIC-OTHER-OEI-VIPER RECLOSERS 2024-HORN DITCH 1267, 1269, & 12-797, GOSHEN GOSHEN LOA PACKET 5, POLE DETAILS

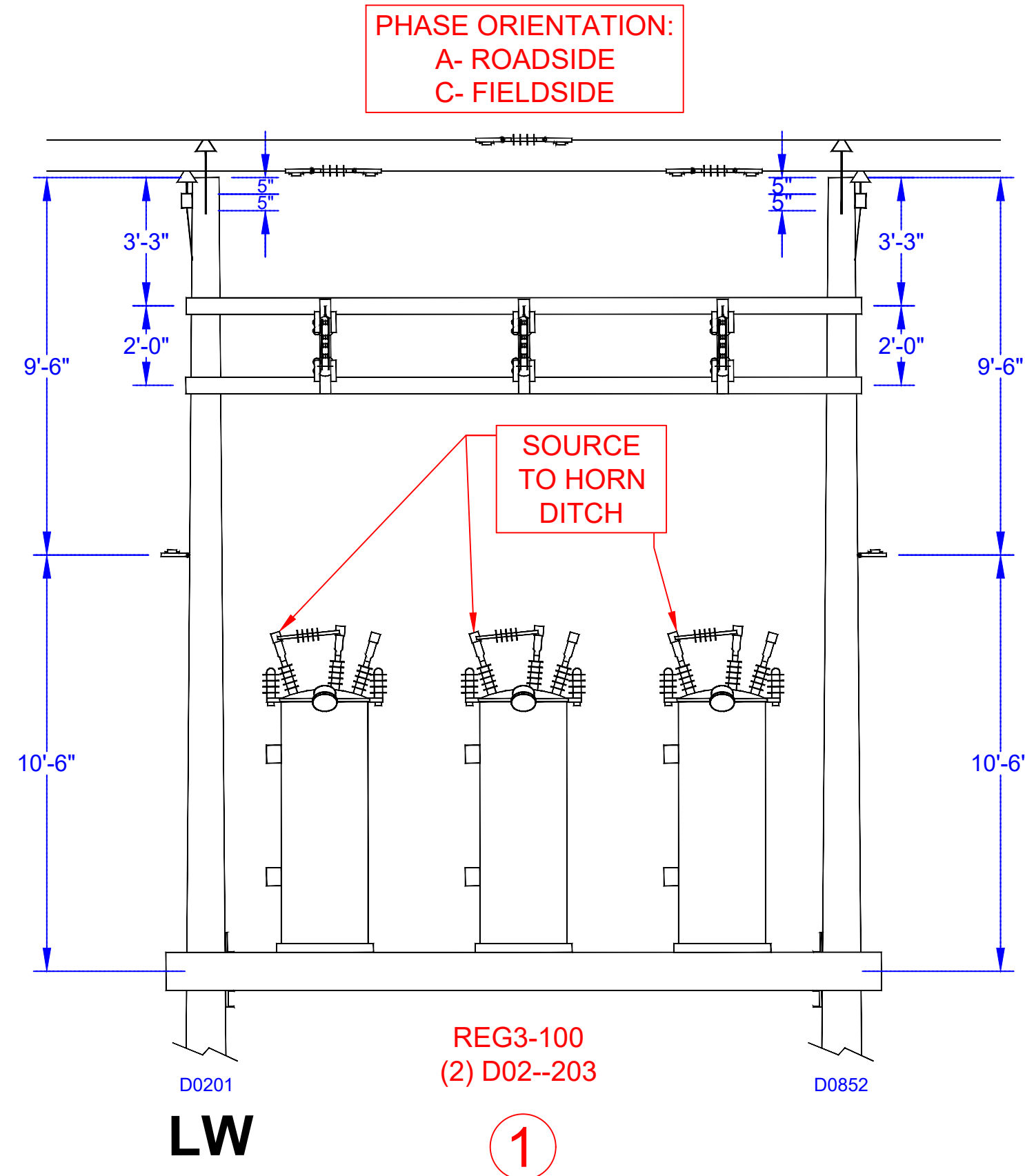
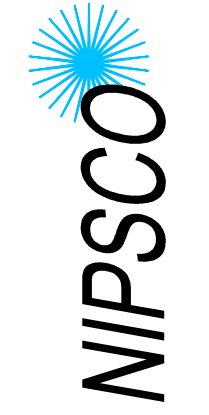

**POLES 1125/211 & 1125/212**

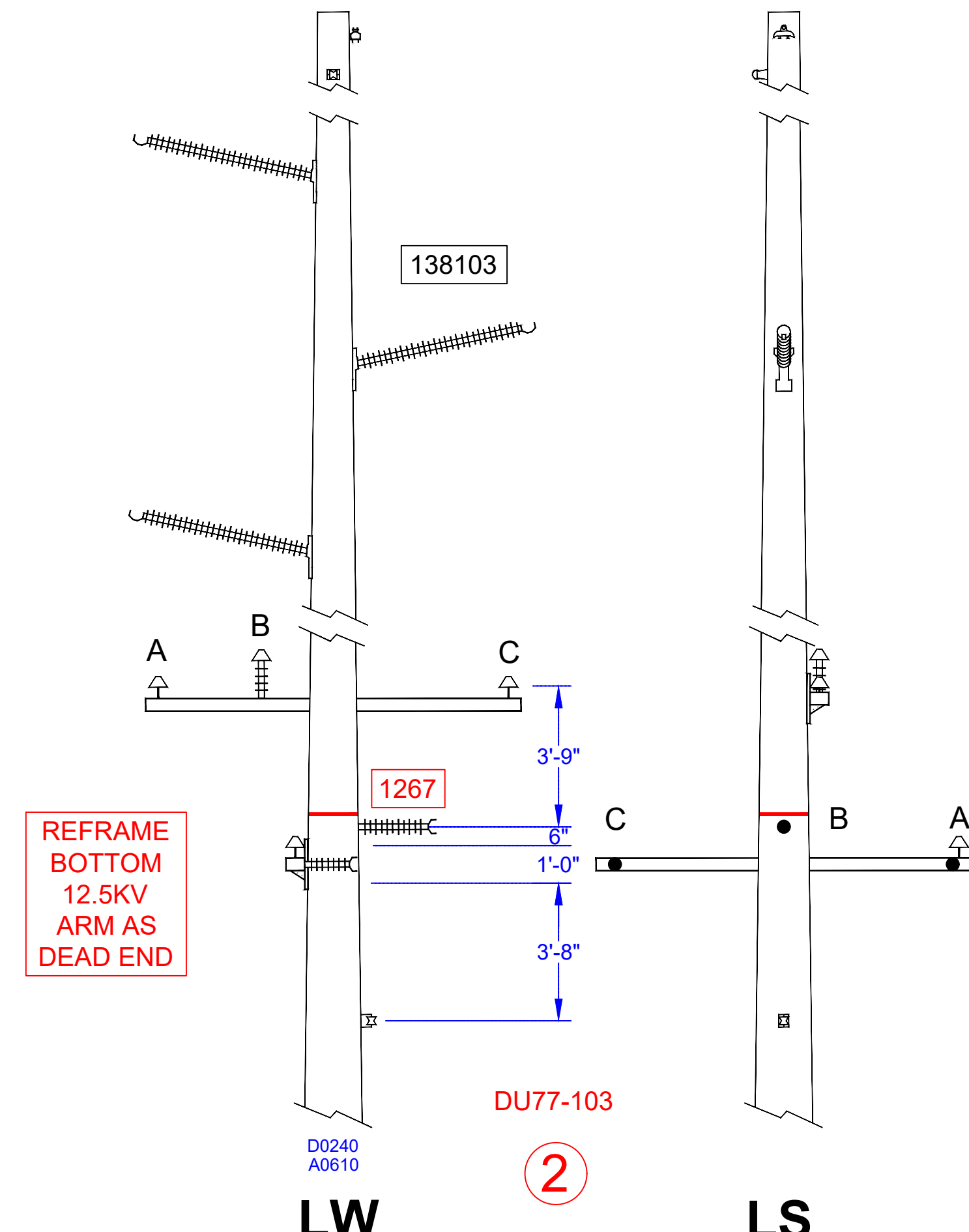

**POLE 695/533**

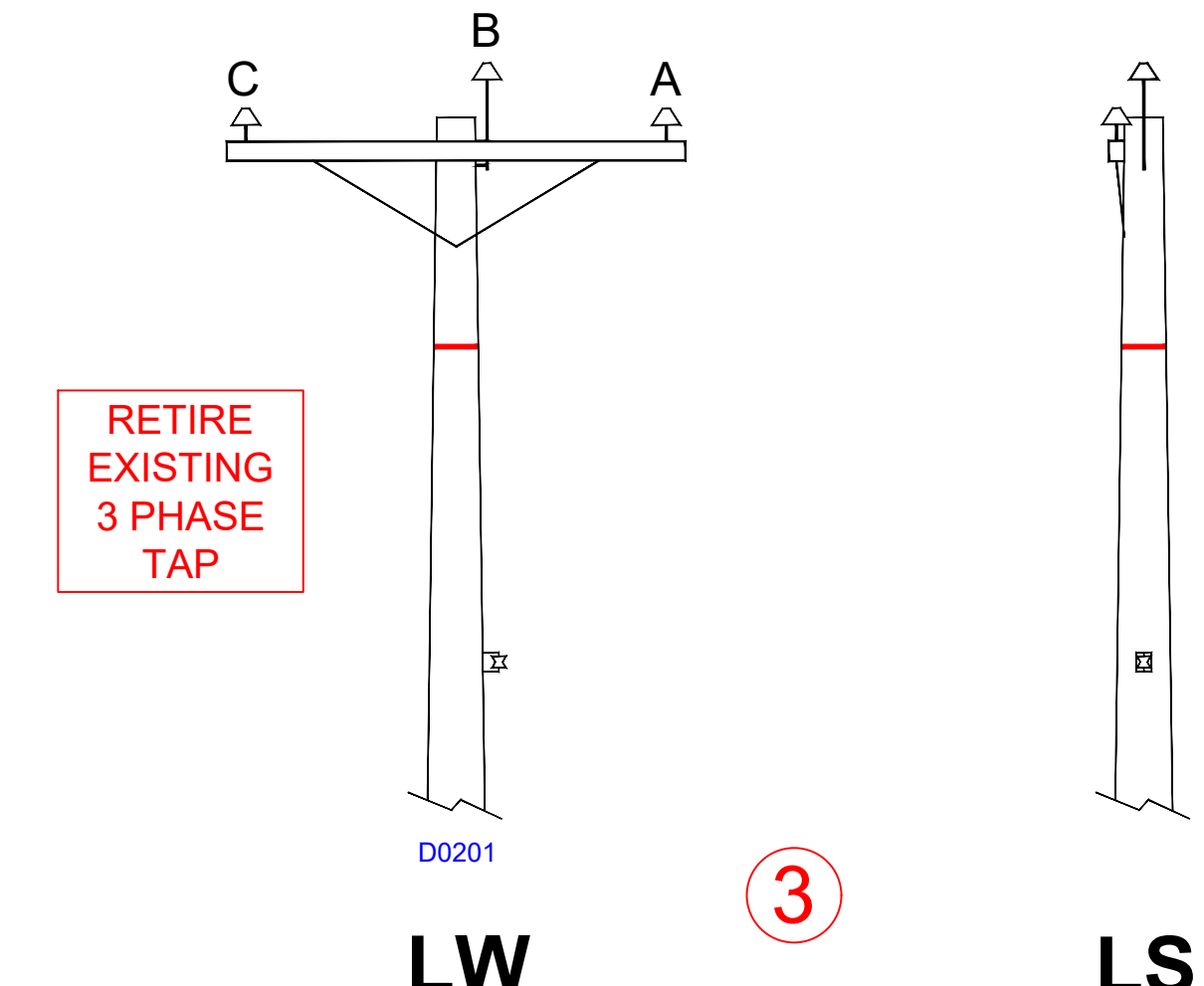

**POLE 1069/263**

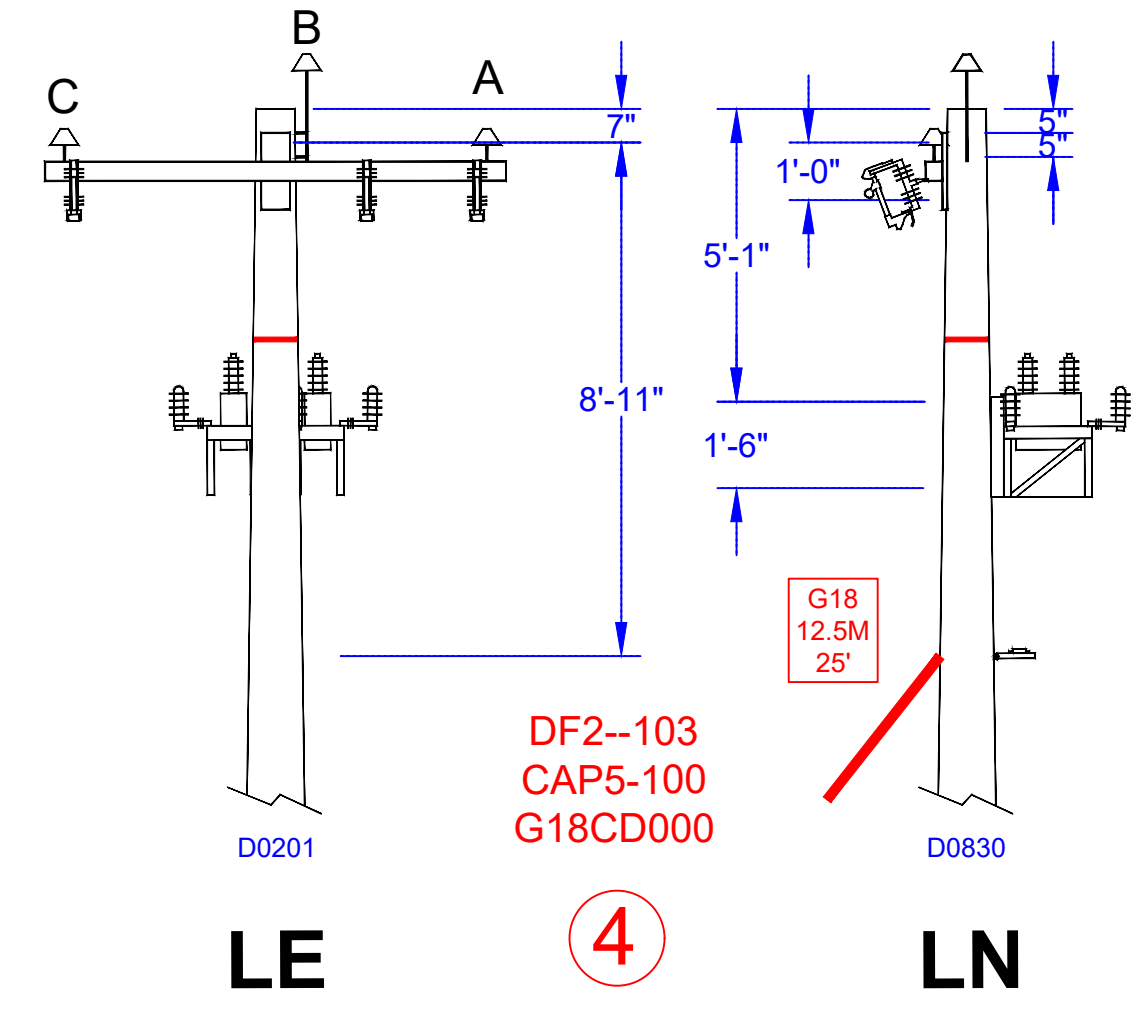

**POLE 1067/808**

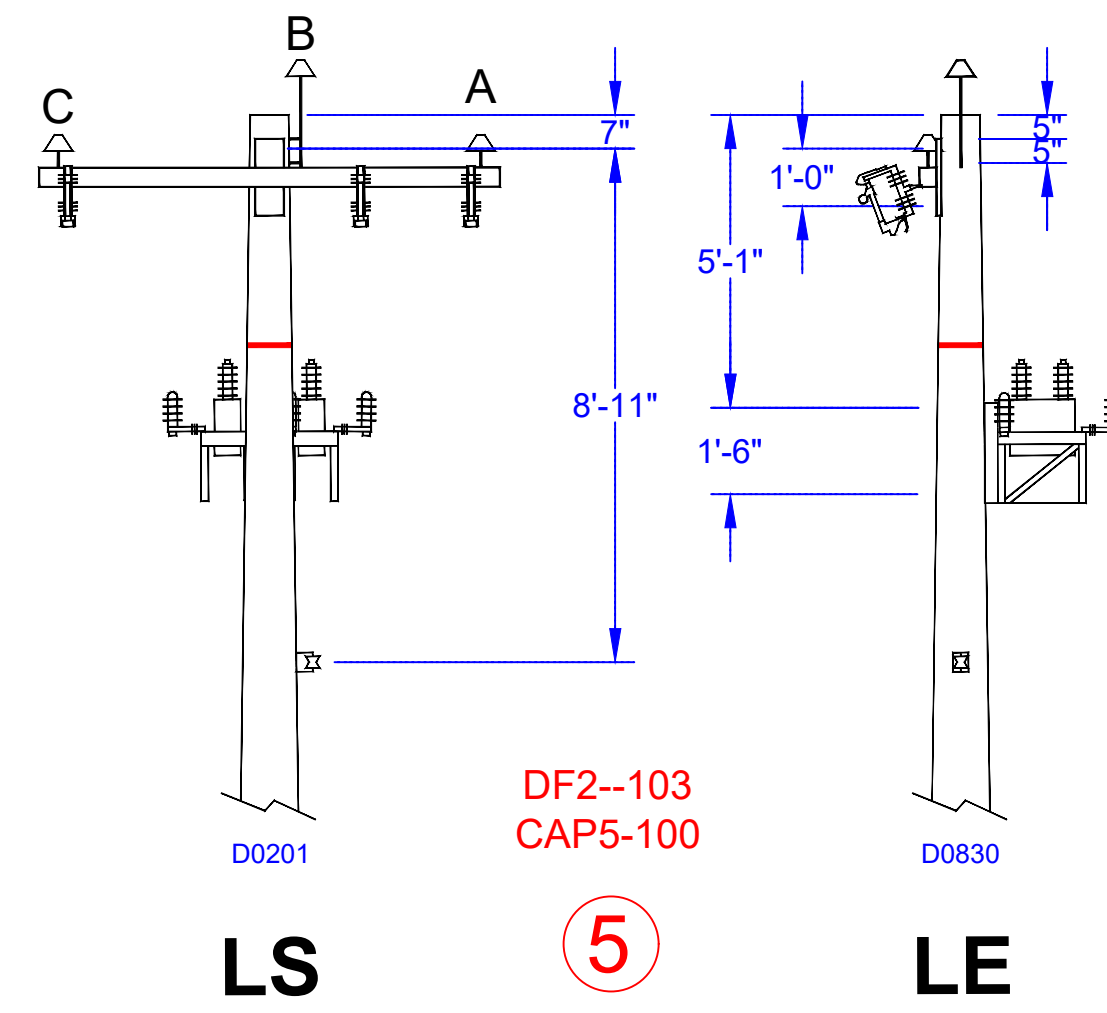

**POLE 1062/096**

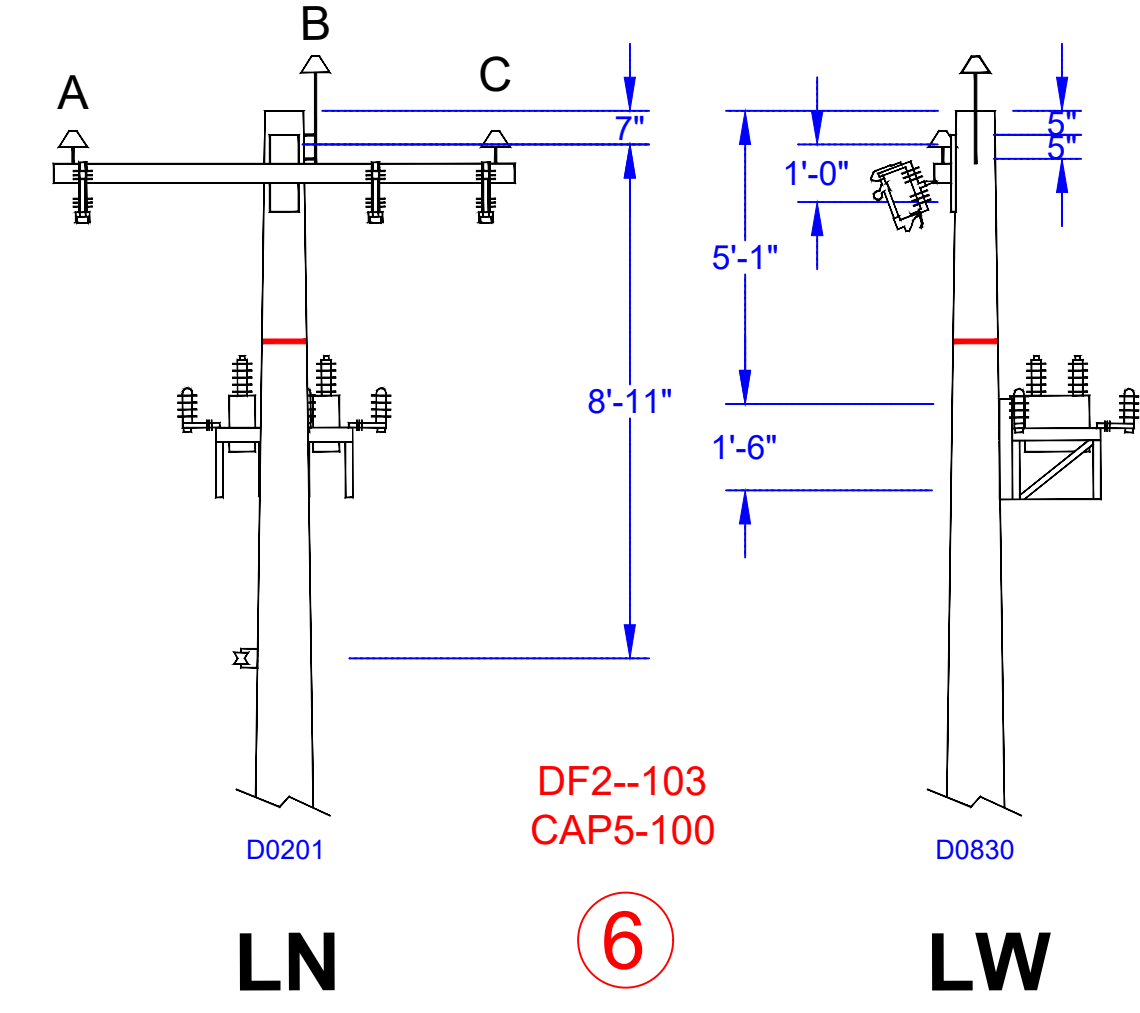

**POLE 678/976**

**NOTE:**  
ALL PHASING CALLOUTS WERE DETERMINED THROUGH MATCHING NEARBY TAPS/TRANSFORMERS WITH GIS DATA AND FIELD CONDITIONS. PHASING SHALL BE VERIFIED AT THE TIME OF CONSTRUCTION.

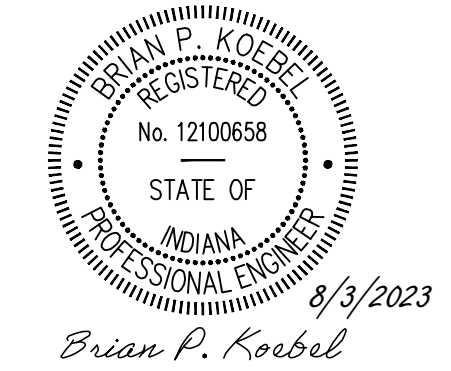

**ISSUED FOR CONSTRUCTION**

REV	DESCRIPTION	PREPARED	REVIEWED	APPROVED	DATE
3	ISSUED FOR CONSTRUCTION	MAP	TJB	BK	08/3/23
2	ISSUED FOR REVIEW 90%	MAP	JDD	BK	07/14/23
1	ISSUED FOR REVIEW 30%	MAP	FP	BK	03/13/23

PROJECT: HAM.22.8648

Revision
3: IFC

**AS BUILT**

ID#: \_\_\_\_\_ DATE: \_\_\_\_\_  
SIGN: \_\_\_\_\_  
COMPANY: \_\_\_\_\_

W.O#: 52991-912  
 M#: M9868469  
 R.WO#: 82991-912  
 SHEET: 6 of 6  
 TOWNSHIP: VARIOUS  
 COUNTY: ELKHART  
 LOCATION: GOSHEN, IN  
 TDSIC-OTHER-OEI-VIPER RECLOSERS 2024 HORN DITCH 1267, 1269, & 12-797, GOSHEN GOSHEN LOA PACKET 5  
 ENGR.: M. PETERS  
 OFFICE: (219) 989-3300  
 CELL: (219) 699-8075  
 TAXING UNIT: G12, G15, G20  
 DRAWN: M. PETERS  
 E-MAIL: MPETERS@ORBITALENGR.COM  
 DATE: 08/03/2023  
 APPROVED: BPK  
 NIPSCO DRAWING  
 SCALE: NTS  
 N/A

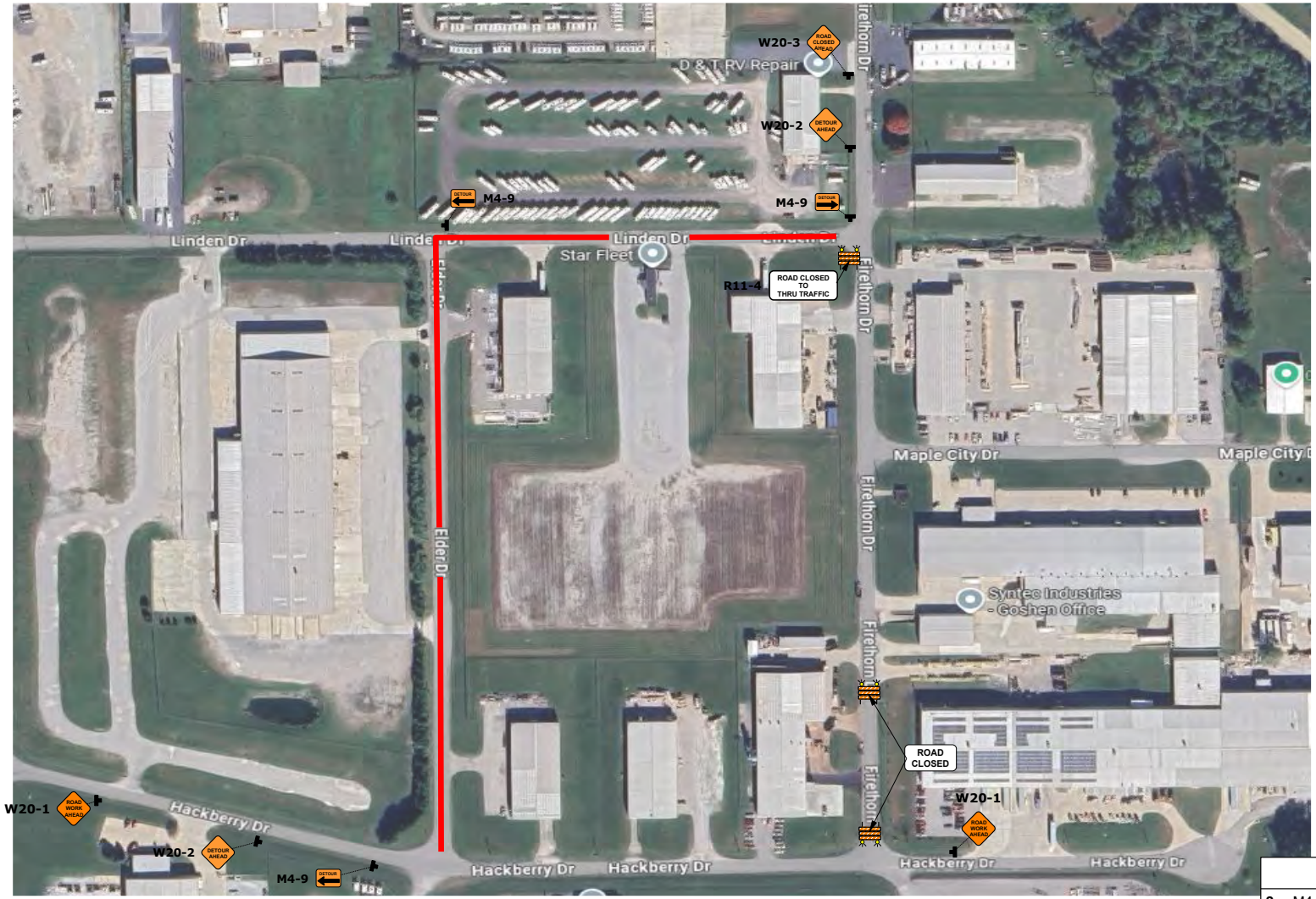

Manifest	
2 x	M4-9 detour (L)
2 x	W20-1 road work ahead
2 x	W20-2 detour ahead
1 x	M4-9 detour (R)
1 x	R11-2 road closed R11-2
1 x	R11-4 road closed to thru traffic
1 x	W20-3 road closed ahead

Date: 8/29/2024 Author: HighStar Traffic Project: Brown St - Portage, IN - Closure/Detour  
 Prepared for: Nipsco Sheet: 1 of 1 Scale: N.T.S.

Comments:  
 Plan provided to meet MUTCD standards, any additional requirements may need to be approved. Plans are non signed, sealed, and are for illustration to governing agency for approval. ▲





## CITY OF GOSHEN LEGAL DEPARTMENT

City Annex  
204 East Jefferson Street, Suite 2  
Goshen, Indiana 46528-3405

Phone (574) 537-3820 • Fax (574) 533-8626 • TDD (574) 534-3185  
[www.goshen.in.gov](http://www.goshen.in.gov)

June 4, 2026

To: Goshen Board of Public Works and Safety

From: Shannon Marks, Legal Compliance Administrator

Subject: Amendment #1 to Contract with the Indiana Department of Transportation for Street Sweeping Services

The City and the Indiana Department of Transportation (INDOT) entered into a Contract on October 7, 2025, under which the Goshen Street Department agreed to sweep 20.6 curb miles of state highways within the city limits a minimum of two times each year.

It is recommended that the Board approve and authorize Mayor Leichty to execute Amendment #1 to this Contract. Amendment #1 increases the amount of compensation to the City for services rendered from \$360 to \$450 per curb mile per year, effective July 1, 2026. In addition to the increase in compensation, INDOT has also made revisions to other Contract provisions. These revisions have been reviewed and are acceptable.

Copies of the October 7, 2025 Contract and Amendment #1 are attached.

### Suggested Motion:

Move to approve and authorize Mayor Leichty to execute Amendment #1 to the Contract with the Indiana Department of Transportation for Street Sweeping Services.

**AMENDMENT #1**  
**To**  
**STREET SWEEPING SERVICES CONTRACT**  
**Between**  
**THE INDIANA DEPARTMENT OF TRANSPORTATION**  
**And**  
**THE CITY OF GOSHEN, INDIANA**

SCM # \_\_\_\_\_

This amendment (“**Amendment #1**”), entered into between the Indiana Department of Transportation (hereinafter referred to as “**State**”) and the City of Goshen (hereinafter referred to as the “**Local Public Agency**” or “**LPA**”), jointly referred to as the “**Parties**,” is executed pursuant to the terms and conditions set forth herein. In consideration of those mutual undertakings and covenants, the parties agree as follows:

**WHEREAS**, on October 7, 2025 the Parties entered into a contract under EDS #ON250208 (“**Contract**”) to keep state highways and curbs clean and free of dirt and debris (“**Services**”) through sweeping services performed by the LPA on state facilities; and

**WHEREAS**, in 2025, the Contract amount for Services was \$360.00 per curb mile per year; and

**WHEREAS**, INDOT has increased the amount for Services and commencing July 1, 2026, the Contract amount for Services is \$450.00 per curb mile per year; and

**WHEREAS**, the Parties have agreed to amend the total remuneration amount to \$35,226.00 to reflect the agreed upon change in per curb mile per year compensation;

**NOW THEREFORE**, in consideration of the mutual covenants contained herein the parties agree as follows.

1. Section 2. of the Contract is deleted in its entirety and is hereby substituted by the following:

**2. Consideration. The State agrees to pay the LPA for Services rendered prior to July 1, 2026, the amount of \$360.00 per curb mile per year. Commencing July 1, 2026 and each year thereafter, INDOT shall pay the LPA \$450.00 per curb mile per year for Services rendered. Total remuneration under this Contract shall not exceed \$35,226.00.**

**The LPA shall submit one (1) invoice to the State each year and the State shall pay the invoice in accordance with its regular fiscal procedures. When submitting the invoice, the LPA shall certify that the Services have been provided.**

2. Section 10. of the Contract is deleted in its entirety and is hereby substituted by the following:

**10. Compliance with Laws.**

**A. The LPA shall comply with all applicable federal, state and local laws, rules, regulations and ordinances, and all provisions required thereby to be included herein are hereby incorporated by reference. The enactment or modification of any applicable state or federal statute or the promulgation of rules or regulations thereunder after execution of this Contract shall be reviewed by the State and the LPA to determine whether the provisions of this Contract require formal modification.**

**B. The LPA and its agents shall abide by all ethical requirements that apply to persons who have a business relationship with the State as set forth in IC § 4-2-6, *et seq.*, IC § 4-2-7, *et seq.* and the regulations promulgated thereunder. If the LPA has knowledge, or would have acquired knowledge with reasonable inquiry, that a state officer, employee, or special state appointee, as those terms are defined in IC § 4-2-6-1, has a financial interest in the Contract, the LPA shall ensure compliance with the disclosure requirements in IC § 4-2-6-10.5 prior to the execution of this Contract. If the LPA is not familiar with these ethical requirements, the LPA should refer any questions to the Indiana State Ethics Commission or visit the Inspector General's website at <http://www.in.gov/ig/>. If the LPA or its agents violate any applicable ethical standards, the State may, in its sole discretion, terminate this Contract immediately upon notice to the LPA. In addition, the LPA may be subject to penalties under IC §§ 4-2-6, 4-2-7, 35-44.1-1-4, and under any other applicable laws.**

**C. [OMITTED – NOT APPLICABLE]**

**D. [OMITTED – NOT APPLICABLE]**

**E. Pursuant to IC § 5-22-3-1, the State and the Contractor shall act in good faith in connection with the performance or administration of or any negotiations undertaken in accordance with or with respect to this Contract.**

**F. The LPA warrants that the LPA and its subcontractors, if any, shall obtain and maintain all required permits, licenses, registrations, and approvals, and shall comply with all health, safety, and environmental statutes, rules, or regulations in the performance of work activities for the State. Failure to do so may be deemed a material breach of this Contract and grounds for immediate termination and denial of further work with the State.**

**G. [OMITTED – NOT APPLICABLE]**

**H. As required by IC 5-22-3-7:**

**(1) The LPA and any principals of the LPA certify that:**

**(A) the LPA, except for de minimis and nonsystematic violations, has not violated the terms of:**

**(i) IC §24-4.7 [Telephone Solicitation Of Consumers];**

**(ii) IC §24-5-12 [Telephone Solicitations]; or**

**(iii) IC §24-5-14 [Regulation of Automatic Dialing Machines];**

**in the previous three hundred sixty-five (365) days, even if IC § 24-4.7 is preempted by federal law; and**

**(B) the LPA will not violate the terms of IC § 24-4.7 for the duration of the Contract, even if IC §24-4.7 is preempted by federal law.**

**(2) The LPA and any principals of the LPA certify that an affiliate or principal of the LPA and any agent acting on behalf of the LPA or on behalf of an affiliate or principal of the LPA, except for de minimis and nonsystematic violations,**

**(A) has not violated the terms of IC § 24-4.7 in the previous three hundred sixty-five (365) days, even if IC §24-4.7 is preempted by federal law; and**

**I. [OMITTED – NOT APPLICABLE]**

3. Section 18. of the Contract is deleted in its entirety and is hereby substituted by the following:

**18. Employment Eligibility Verification.** As a condition precedent to entering this contract, and as required by IC § 22-5-1.7 and Executive Order 25-29, the LPA swears or affirms under the penalties of perjury that the LPA has not knowingly employed, and will not knowingly employ, an unauthorized alien. The LPA further affirms that:

**A.** The LPA has enrolled in, and verified, the work eligibility status of all its employees through, the E-Verify program as defined in IC § 22-5-1.7-3. The LPA is not required to participate should the E-Verify program cease to exist. Additionally, the LPA is not required to participate if the LPA is self-employed and does not employ any employees.

**B.** The LPA has not knowingly employed or contracted with, and shall not knowingly employ or contract with, an unauthorized alien. The LPA has not retained, and shall not retain, an employee, and has not contracted and shall not contract with a person, that the LPA subsequently learned or learns is an unauthorized alien.

**C.** The LPA has required and shall require its subcontractors, who perform work under this Contract, to certify to the LPA that the subcontractor does not knowingly employ or contract with an unauthorized alien and that the subcontractor has enrolled and is participating in the E-Verify program. The LPA agrees to maintain this certification throughout the duration of the term of a contract with a subcontractor and to provide any and all such certifications to the State promptly upon request.

The State may terminate this Contract for default if the LPA fails to cure a breach of this provision no later than thirty (30) days after being notified by the State.

4. Section 21. of the Contract is deleted in its entirety and is hereby substituted by the following:

**21. Funding Cancellation.**

**A.** As required by Financial Management Circular 3.3 and IC § 5-22-17-5, when the Director of the State Budget Agency makes a written determination that funds are not appropriated or otherwise available to support continuation of performance of this Contract, this Contract shall be canceled. A determination by the Director of the State Budget Agency that funds are not appropriated or otherwise available to support continuation of performance shall be final and conclusive. The date of such written determination shall be the effective date of cancellation.

**B.** If the funds specified in this Contract for paying the LPA come solely from sources other than State funds and the State Budget Agency or the INDOT Commissioner makes a written determination that there are no longer any available funds from such sources to support continuation of performance of this Contract, this Contract shall be canceled. A determination by the State Budget Agency or such officer of the State that such funds are not otherwise available to support continuation of performance shall be final and conclusive. The date of such written determination shall be the effective date of cancellation.

**C.** The LPA shall be compensated for completed supplies properly delivered, if any, and Services properly rendered prior to the effective date of cancellation. The State will

**not be liable for supplies delivered or Services performed after the effective date of cancellation. The LPA and the State shall agree on the amount of payment for such supplies delivered and accepted. The State may withhold from these amounts any sum the State determines to be necessary to protect the State against loss because of outstanding liens or claims of former lien holders. Failure to agree on any item in this subparagraph constitutes a dispute under the Disputes paragraph. With the exception of any item in this subparagraph on which the LPA and the State fail to agree, no other item in this paragraph shall constitute a dispute under the Disputes paragraph.**

5. Section 33. of the Contract is deleted in its entirety and is hereby substituted by the following:

**33. Nondiscrimination. Pursuant to the Indiana Civil Rights Law, specifically IC § 22-9-1-10, and in keeping with the purposes of the federal Civil Rights Acts of 1964, the Age Discrimination Act in Employment Act, and the Americans with Disabilities Act:**

**A. The LPA covenants that it shall not discriminate against any employee or applicant for employment relating to this Contract with respect to the hire, tenure, terms, conditions or privileges of employment or any matter directly or indirectly related to employment, because of the employee's or applicant's race, color, national origin, religion, sex, age, disability, ancestry, status as a veteran, or any other characteristic protected by federal, state, or local law ("Protected Characteristics"). The LPA certifies compliance with applicable federal laws, regulations, and executive orders prohibiting discrimination based on the Protected Characteristics in the provision of services. Breach of this subparagraph may be regarded as a material breach of this Contract, including for purposes of Indiana Code § 5-11-5.5-2, but nothing in this paragraph shall be construed to imply or establish an employment relationship between the State and any applicant or employee of the LPA or any subcontractor.**

**B. LPA covenants that it does not and shall not operate any programs or engage in any practices promoting Diversity, Equity, and Inclusion (DEI), or other similar goals, that violate Indiana or Federal Civil Rights Laws by treating a person differently on the basis of race or sex, such as by considering race or sex when making recruitment, hiring, disciplinary, promotion, or employment decisions; requiring employees to participate in training or educational programs that employ racial or sex stereotypes; or attempting to achieve racial or sex balancing in the LPA's workforce. The Parties agree that a breach of this subparagraph is a material breach of this Contract, including for purposes of Indiana Code § 5-11-5.5-2, but nothing in this paragraph shall be construed to imply or establish an employment relationship between the State and any applicant or employee of the LPA or any subcontractor.**

6. Section 34. of the Contract is deleted in its entirety and is hereby substituted by the following:

**34. Notice to Parties.**

**A. i. Whenever any notice, statement, request, consent or other communication is required under this Contract (each, a "Notice"), it shall be effective only if it is in writing and: (a) personally delivered; or (b) sent by: (I) email; (II) first class U.S. mail service; or (III) a nationally recognized overnight delivery service, with delivery confirmed and costs of**

delivery being prepaid; to the following addresses, or to such other address or addresses as shall be furnished in writing by any party to the other party.

**ii. Notices to the State shall be sent to:**

Indiana Department of Transportation – Fort Wayne District

ATTN: Jenny Bass, Finance Director

Telephone: 260-969-8209

Email: [jbass@indot.in.gov](mailto:jbass@indot.in.gov)

5333 Hatfield Road, Fort Wayne, IN 46808

**iii. Notices to the LPA shall be sent to:**

City of Goshen

ATTN: Clerk- Treasurer, Richard Aguirre

Address: 202 S. 5th Str., Goshen, IN 46528

Telephone: 574-533-8625

Email: [richardaguirre@goshencity.com](mailto:richardaguirre@goshencity.com)

iv. Unless the sending party has actual knowledge that a Notice was not received by the intended recipient, a Notice shall be deemed to have been given as of the date (a) when personally delivered; (b) when sent in the case of an email properly addressed; (c) three (3) days after the date deposited with the United States mail properly addressed; or (d) the next day when delivered during business hours to an overnight delivery service, properly addressed and prior to such delivery service's cut off time for next day delivery. The parties acknowledge that Notices delivered by facsimile shall not be effective.

As required by IC 4-13-2-14.8, payments to the LPA shall be made via electronic funds transfer in accordance with instructions filed by the LPA with the Indiana Auditor of State.

7. Section 45. of the Contract is deleted in its entirety and is hereby substituted by the following:

**45. Termination for Convenience.**

A. This Contract may be terminated, in whole or in part, by the State, which shall include and is not limited to IDOA and the State Budget Agency whenever, for any reason, the State determines that such termination is in its best interest. Termination of the delivery of supplies, if any, or the rendering of Services shall be effected by the delivery to the LPA of a termination notice thirty (30) days prior to the effective date of termination, specifying the extent to which the delivery of such supplies and the performance of such Services under such termination becomes effective. In connection with the termination notice, the State shall send a copy thereof to the Commissioner.

B. The LPA shall be compensated for Services properly rendered prior to the effective date of termination. The State will not be liable for Services performed after the effective date of termination. The State may withhold from these amounts any sum the State determines to be necessary to protect the State against loss because of outstanding liens or claims of former lien holders. The LPA shall be compensated for Services provided in accordance with this Contract, but in no case shall the total payment made to the LPA exceed the original contract price or shall any price increase be allowed on individual line items, if any such Services were

**canceled only in part prior to the original termination date. Failure to agree on any item in this subparagraph constitutes a dispute under the Disputes paragraph.**

**C. The rights and remedies of the State in this paragraph are in addition to any other rights and remedies provided by law or equity or under this Contract.**

8. All other matters previously agreed to and set forth in the original Contract and not affected by this Amendment #1 shall remain in full force and effect.

**Non-Collusion and Acceptance**

The undersigned attests, subject to the penalties for perjury, that he/she is the properly authorized representative, agent, member or officer of the LPA, that he/she has not, nor has any other member, employee, representative, agent or officer of the LPA, directly or indirectly, to the best of his/her knowledge, entered into or offered to enter into any combination, collusion or agreement to receive or pay, and that he/she has not received or paid, any sum of money or other consideration for the execution of this Agreement other than that which appears upon the face of this Agreement. **Furthermore, if the undersigned has knowledge that a state officer, employee, or special state appointee, as those terms are defined in IC §4-2-6-1, has a financial interest in the Agreement, the LPA attests to compliance with the disclosure requirements in IC §4-2-6-10.5.**

**Agreement to Use Electronic Signatures**

I agree, and it is my intent, to sign this Agreement by accessing State of Indiana Supplier Portal using the secure password assigned to me and by electronically submitting this Agreement to the State of Indiana. I understand that my signing and submitting this Agreement in this fashion is the legal equivalent of having placed my handwritten signature on the submitted Agreement and this affirmation. I understand and agree that by electronically signing and submitting this Agreement in this fashion I am affirming to the truth of the information contained therein. I understand that this Agreement will not become binding on the State until it has been approved by the Department of Administration, the State Budget Agency, and the Office of the Attorney General, which approvals will be posted on the Active Contracts Database: [https://fs.gmis.in.gov/psp/guest/SUPPLIER/ERP/c/SOI\\_CUSTOM\\_APPS.SOI\\_PUBLIC\\_CNTRCTS.GBL](https://fs.gmis.in.gov/psp/guest/SUPPLIER/ERP/c/SOI_CUSTOM_APPS.SOI_PUBLIC_CNTRCTS.GBL)

**In Witness Whereof**, the LPA and the State have, through duly authorized representatives, entered into this Contract. The parties, having read and understand the foregoing terms of this Contract, do by their respective signatures dated below hereby agree to the terms thereof.

**LPA**

Name of LPA: City of Goshen  
Signature: \_\_\_\_\_  
Printed Name: \_\_\_\_\_  
Title: \_\_\_\_\_  
Date: \_\_\_\_\_

**STATE OF INDIANA  
Indiana Department of Transportation**

\_\_\_\_\_ (for)  
Lyndsay Quist, Commissioner

**Date:** \_\_\_\_\_

**STATE APPROVALS**

*\*All State Approvals are made electronically – see attached confirmation page.\**

**APPROVALS**

**Department of Administration**

\_\_\_\_\_ (for)  
Brandon Clifton, Commissioner

**Date:** \_\_\_\_\_

**Budget Agency**

\_\_\_\_\_ (for)  
Chad Ranney, State Budget Director

**Date:** \_\_\_\_\_

**APPROVED as to Form and Legality:  
Office of the Attorney General**

\_\_\_\_\_ (for)  
Theodore E. Rokita, Attorney General

**Date:** \_\_\_\_\_

**STREET SWEEPING SERVICES**  
**EDS/SCM# 000000000000000000095795**

This Contract, entered into by and between the Indiana Department of Transportation (hereinafter referred to as “State”) and the City of Goshen, Indiana (hereinafter referred to as the “Local Public Agency” or “LPA”), is executed pursuant to the terms and conditions set forth herein.

WHEREAS, the State needs sweeping services to keep state highways and curbs clean and free of dirt and debris; and

WHEREAS, the LPA has the required sweeping capabilities and is willing to perform sweeping services on state facilities pursuant to this Contract;

NOW THEREFORE, in consideration of the mutual covenants contained herein the parties agree as follows.

**1. Duties of LPA.** The LPA agrees to perform all services necessary to keep the following described state roads, highways and curbs clean and free of dirt and debris (include road, location, curb miles, etc.):

SR 119 for 1.1 curb miles

SR 15 for 6.7 curb miles

US 33 for 12.8 curb miles

**Total curb miles: 20.6**

a) The LPA agrees to dispose of all dirt and debris collected in the cleaning process. All cleaning and disposal of dirt and debris shall be to the reasonable satisfaction of the Indiana Department of Transportation’s District Director or his/her designee. The LPA shall take proper precautions and be responsible for the safe performance of the work covered by this Contract. Furthermore, the LPA agrees to comply with all applicable federal, state and local laws, rules, regulations and ordinances in the performance of its work under this Contract.

b) **Each location shall be cleaned a minimum of two (2) times per year.**

c) The LPA shall be responsible for all liability due to loss, damage, injuries, or other casualties to persons or property arising out of the work performed pursuant to this Contract, whether due in whole or in part to the negligent acts or omissions of the LPA, its agents or employees, or other persons engaged in the performance of the work, including any claims arising out of the Worker’s Compensation Act.

**2. Consideration.** The State agrees to pay the LPA \$360 per curb mile per year, for a total of **\$7,416.00** per year. Total remuneration under this Contract shall not exceed **\$29,664.00**.

The LPA shall submit one (1) invoice to the State each **year** and the State shall pay the invoice in accordance with its regular fiscal procedures. **When submitting the invoice, the LPA shall certify that the service(s) has been provided.**

**3. Term.** This Contract shall be effective for a period of **forty-eight (48)** months. It shall commence on July 1, 2025, and shall remain in effect through June 30, 2029.

**4. Access to Records.** The LPA and its subcontractors, if any, shall maintain all books, documents, papers, accounting records, and other evidence pertaining to all costs incurred under this Contract. They shall make such materials available at their respective offices at all reasonable times during this Contract, and for three (3) years from the date of final payment under this Contract, for inspection by the State or its authorized designees. Copies shall be furnished at no cost to the State if requested.

**5. Assignment; Successors.**

A. The LPA binds its successors and assignees to all the terms and conditions of this Contract. The LPA may assign its right to receive payments to such third parties as the LPA may desire without the prior written consent of the State, provided that the LPA gives written notice (including evidence of such assignment) to the State thirty (30) days in advance of any payment so assigned. The assignment shall cover all unpaid amounts under this Contract and shall not be made to more than one party.

B. The LPA shall not assign or subcontract the whole or any part of this Contract without the State's prior written consent. Additionally, the LPA shall provide prompt written notice to the State of any change in the LPA's legal name or legal status so that the changes may be documented and payments to the successor entity may be made.

**6. Assignment of Antitrust Claims.** [OMITTED – NOT APPLICABLE].

**7. Audits.** The LPA acknowledges that it may be required to submit to an audit of funds paid through this Contract. Any such audit shall be conducted in accordance with IC 5-11-1, et. seq. and audit guidelines specified by the State.

The State considers the LPA to be a "LPA" under 2 C.F.R. 200.330 for purposes of this Contract. However, if it is determined that the LPA is a "subrecipient" and if required by applicable provisions of 2 C.F.R. 200 (Uniform Administrative Requirements, Cost Principles, and Audit Requirements), LPA shall arrange for a financial and compliance audit, which complies with 2 C.F.R. 200.500 *et seq.*

**8. Authority to Bind the LPA.** The signatory for the LPA represents that he/she has been duly authorized to execute this Contract on behalf of the LPA and has obtained all necessary or applicable approvals to make this Contract fully binding upon the LPA when his/her signature is affixed and accepted by the State.

**9. Changes in Work.** The LPA shall not commence any additional work or change the scope of the work until authorized in writing by the State. The LPA shall make no claim for additional compensation in the absence of a prior written approval and amendment executed by all signatories hereto. This Contract may only be amended, supplemented or modified by a written document executed in the same manner as this Contract.

**10. Compliance with Laws.**

A. The LPA shall comply with all applicable federal, state and local laws, rules, regulations and ordinances, and all provisions required thereby to be included herein are hereby incorporated by reference. The enactment or modification of any applicable state or federal statute or the promulgation of rules or regulations thereunder after execution of this Contract shall be reviewed by the State and the LPA to determine whether the provisions of this Contract require formal modification.

B. The LPA and its agents shall abide by all ethical requirements that apply to persons who have a business relationship with the State as set forth in IC § 4-2-6, *et seq.*, IC § 4-2-7, *et seq.* and the regulations promulgated thereunder. **If the LPA has knowledge, or would have acquired knowledge with reasonable inquiry, that a state officer, employee, or special state appointee, as those terms are defined in IC § 4-2-6-1, has a financial interest in the Contract, the LPA shall ensure compliance with the disclosure requirements in IC § 4-2-6-10.5 prior to the execution of this Contract.** If the LPA is not familiar with these ethical requirements, the LPA should refer any questions to the Indiana State Ethics Commission or visit the Inspector General's website at <http://www.in.gov/ig/>. If the LPA or its agents violate any applicable ethical standards, the State may, in its sole discretion, terminate this Contract immediately upon notice to the LPA. In addition, the LPA may be subject to penalties under IC §§ 4-2-6, 4-2-7, 35-44.1-1-4, and under any other applicable laws.

C. The LPA certifies by entering into this Contract that neither it nor its principal(s) is presently in arrears in payment of taxes, permit fees or other statutory, regulatory or judicially required payments to the State. The LPA agrees that any payments currently due to the State may be withheld from payments due to the LPA. Additionally, further work or payments may be withheld, delayed, or denied and/or this Contract suspended until the LPA is current in its payments and has submitted proof of such payment to the State.

D. The LPA warrants that it has no current, pending or outstanding criminal, civil, or enforcement actions initiated by the State, and agrees that it will immediately notify the State of any such actions. During the term of such actions, the LPA

agrees that the State may delay, withhold, or deny work under any supplement, amendment, change order or other contractual device issued pursuant to this Contract.

E. If a valid dispute exists as to the LPA's liability or guilt in any action initiated by the State or its agencies, and the State decides to delay, withhold, or deny work to the LPA, the LPA may request that it be allowed to continue, or receive work, without delay. The LPA must submit, in writing, a request for review to the Indiana Department of Administration (IDOA) following the procedures for disputes outlined herein. A determination by IDOA shall be binding on the parties. Any payments that the State may delay, withhold, deny, or apply under this section shall not be subject to penalty or interest, except as permitted by IC § 5-17-5.

F. The LPA warrants that the LPA and its subcontractors, if any, shall obtain and maintain all required permits, licenses, registrations, and approvals, and shall comply with all health, safety, and environmental statutes, rules, or regulations in the performance of work activities for the State. Failure to do so may be deemed a material breach of this Contract and grounds for immediate termination and denial of further work with the State.

G. The LPA affirms that, if it is an entity described in IC Title 23, it is properly registered and owes no outstanding reports to the Indiana Secretary of State.

H. As required by IC 5-22-3-7:

(1) The LPA and any principals of the LPA certify that:

(A) the LPA, except for de minimis and nonsystematic violations, has not violated the terms of:

(i) IC §24-4.7 [Telephone Solicitation Of Consumers];

(ii) IC §24-5-12 [Telephone Solicitations]; or

(iii) IC §24-5-14 [Regulation of Automatic Dialing Machines];

in the previous three hundred sixty-five (365) days, even if IC § 24-4.7 is preempted by federal law; and

(B) the LPA will not violate the terms of IC § 24-4.7 for the duration of the Contract, even if IC §24-4.7 is preempted by federal law.

(2) The LPA and any principals of the LPA certify that an affiliate or principal of the LPA and any agent acting on behalf of the LPA or on behalf of an affiliate or principal of the LPA, except for de minimis and nonsystematic violations,

(A) has not violated the terms of IC § 24-4.7 in the previous three hundred sixty-five (365) days, even if IC §24-4.7 is preempted by federal law; and

(I) will not violate the terms of IC § 24-4.7 for the duration of the Contract, even if IC §24-4.7 is preempted by federal law.

**11. Condition of Payment.** All services provided by the LPA under this Contract must be performed to the State's reasonable satisfaction, as determined at the discretion of the undersigned State representative and in accordance with all applicable federal, state, local laws, ordinances, rules and regulations. The State shall not be required to pay for work found to be unsatisfactory, inconsistent with this Contract or performed in violation of and federal, state or local statute, ordinance, rule or regulation.

**12. Confidentiality of State Information.** [OMITTED – NOT APPLICABLE].

**13. Continuity of Services.** [OMITTED – NOT APPLICABLE].

**14. Debarment and Suspension.**

A. The LPA certifies by entering into this Contract that neither it nor its principals nor any of its subcontractors are presently debarred, suspended, proposed for debarment, declared ineligible or voluntarily excluded from entering into this Contract by any federal agency or by any department, agency or political subdivision of the State. The term "principal" for purposes of this Contract means an officer, director, owner, partner, key employee or other person with primary management or supervisory responsibilities, or a person who has a critical influence on or substantive control over the operations of the LPA.

B. The LPA certifies that it has verified the state and federal suspension and debarment status for all subcontractors receiving funds under this Contract and shall be solely responsible for any recoupment, penalties or costs that might arise from use of a suspended or debarred subcontractor. The LPA shall immediately notify the State if any subcontractor becomes debarred or suspended, and shall, at the State's request, take all steps required by the State to terminate its contractual relationship with the subcontractor for work to be performed under this Contract.

**15. Default by State.** [OMITTED – NOT APPLICABLE].

**16. Disputes.** [OMITTED – NOT APPLICABLE].

**17. Drug-Free Workplace Certification.** As required by Executive Order No. 90-5 dated April 12, 1990, issued by the Governor of Indiana, the LPA hereby covenants and agrees to make a good faith effort to provide and maintain a drug-free workplace. The LPA will give written notice to the State within ten (10) days after receiving actual notice that the LPA, or an employee of the LPA in the State of Indiana, has been convicted of a criminal drug violation occurring in the workplace. False certification or violation of this certification may result in sanctions including, but not limited to, suspension of contract payments, termination of this Contract and/or debarment of contracting opportunities with the State for up to three (3) years.

In addition to the provisions of the above paragraph, if the total amount set forth in this Contract is in excess of \$25,000.00, the LPA certifies and agrees that it will provide a drug-free workplace by:

- A. Publishing and providing to all of its employees a statement notifying them that the unlawful manufacture, distribution, dispensing, possession or use of a controlled substance is prohibited in the LPA's workplace, and specifying the actions that will be taken against employees for violations of such prohibition;
- B. Establishing a drug-free awareness program to inform its employees of: (1) the dangers of drug abuse in the workplace; (2) the LPA's policy of maintaining a drug-free workplace; (3) any available drug counseling, rehabilitation and employee assistance programs; and (4) the penalties that may be imposed upon an employee for drug abuse violations occurring in the workplace;
- C. Notifying all employees in the statement required by subparagraph (A) above that as a condition of continued employment, the employee will: (1) abide by the terms of the statement; and (2) notify the LPA of any criminal drug statute conviction for a violation occurring in the workplace no later than five (5) days after such conviction;
- D. Notifying the State in writing within ten (10) days after receiving notice from an employee under subdivision (C)(2) above, or otherwise receiving actual notice of such conviction;
- E. Within thirty (30) days after receiving notice under subdivision (C)(2) above of a conviction, imposing the following sanctions or remedial measures on any employee who is convicted of drug abuse violations occurring in the workplace: (1) taking appropriate personnel action against the employee, up to and including termination; or (2) requiring such employee to satisfactorily participate in a drug abuse assistance or rehabilitation program approved for such purposes by a federal, state or local health, law enforcement, or other appropriate agency; and
- F. Making a good faith effort to maintain a drug-free workplace through the implementation of subparagraphs (A) through (E) above.

**18. Employment Eligibility Verification.** As required by IC § 22-5-1.7, the LPA swears or affirms under the penalties of perjury that the LPA does not knowingly employ an unauthorized alien. The LPA further agrees that:

A. The LPA shall enroll in and verify the work eligibility status of all his/her/its newly hired employees through the E-Verify program as defined in IC § 22-5-1.7-3. The LPA is not required to participate should the E-Verify program cease to exist. Additionally, the LPA is not required to participate if the LPA is self-employed and does not employ any employees.

B. The LPA shall not knowingly employ or contract with an unauthorized alien. The LPA shall not retain an employee or contract with a person that the LPA subsequently learns is an unauthorized alien.

C. The LPA shall require his/her/its subcontractors, who perform work under this Contract, to certify to the LPA that the subcontractor does not knowingly employ or contract with an unauthorized alien and that the subcontractor has enrolled and is participating in the E-Verify program. The LPA agrees to maintain this certification throughout the duration of the term of a contract with a subcontractor.

The State may terminate for default if the LPA fails to cure a breach of this provision no later than thirty (30) days after being notified by the State.

**19. Employment Option.** [OMITTED – NOT APPLICABLE].

**20. Force Majeure.** In the event that either party is unable to perform any of its obligations under this Contract or to enjoy any of its benefits because of natural disaster or decrees of governmental bodies not the fault of the affected party (hereinafter referred to as a “Force Majeure Event”), the party who has been so affected shall immediately give notice to the other party and shall do everything possible to resume performance. Upon receipt of such notice, all obligations under this Contract shall be immediately suspended. If the period of nonperformance exceeds thirty (30) days from the receipt of notice of the Force Majeure Event, the party whose ability to perform has not been so affected may, by giving written notice, terminate this Contract.

**21. Funding Cancellation.** As required by Financial Management Circular 3.3 and IC § 5-22-17-5, when the Director of the State Budget Agency makes a written determination that funds are not appropriated or otherwise available to support continuation of performance of this Contract, this Contract shall be canceled. A determination by the Director of State Budget Agency that funds are not appropriated or otherwise available to support continuation of performance shall be final and conclusive.

**22. Governing Law.** This Contract shall be governed, construed, and enforced in accordance with the laws of the State of Indiana, without regard to its conflict of laws rules. Suit, if any, must be brought in the State of Indiana.

**23. HIPAA Compliance.** [OMITTED – NOT APPLICABLE.]

**24. Indemnification.** The LPA agrees to indemnify, defend, and hold harmless the State, its agents, officials, and employees from all third-party claims and suits including court costs, attorney’s fees, and other expenses caused by any act or omission of the LPA and/or its subcontractors, if any, in the performance of this Contract. The State will not provide indemnification to the LPA.

**25. Independent Contractor; Workers’ Compensation Insurance.** The LPA is performing as an independent entity under this Contract. No part of this Contract shall be construed to represent the creation of an employment, agency, partnership or joint venture agreement between the parties. Neither party will assume liability for any injury (including death) to any persons, or damage to any property, arising out of the acts or omissions of the agents, employees or subcontractors of the other party. The LPA shall provide all necessary unemployment and workers’ compensation insurance for the LPA’s employees, and LPA shall provide the State with a Certificate of Insurance evidencing such coverage prior to starting work under this Contract.

**26. Indiana Veteran Owned Small Business Enterprise Compliance.** [OMITTED – NOT APPLICABLE].

**27. Information Technology Enterprise Architecture Requirements.** [OMITTED – NOT APPLICABLE].

**28. Insurance.** [OMITTED – NOT APPLICABLE].

**29. Key Person(s).** [OMITTED – NOT APPLICABLE].

**30. Licensing Standards.** [OMITTED – NOT APPLICABLE].

**31. Merger & Modification.** This Contract constitutes the entire agreement between the parties. No understandings, agreements, or representations, oral or written, not specified within this Contract will be valid provisions of this Contract. This Contract may not be modified, supplemented or amended, except by written agreement signed by all necessary parties.

**32. Minority and Women’s Business Enterprises Compliance.** [OMITTED – NOT APPLICABLE].

**33. Nondiscrimination.**

- A. Pursuant to the Indiana Civil Rights Law, specifically including IC §22-9-1-10, and in keeping with the purposes of the Civil Rights Act of 1964, the Age Discrimination in Employment Act, and the Americans with Disabilities Act (“ADA”), the LPA covenants that it shall not discriminate against any employee or applicant for employment relating to this Agreement with respect to the hire, tenure, terms, conditions or privileges of employment or any matter directly or indirectly related to employment, because of the employee’s or applicant’s race, color, national origin, religion, sex, age, disability, ancestry, or status as a veteran or any other characteristic protected by federal, state or local law (“Protected Characteristics”). The LPA certifies compliance with applicable federal laws, regulations and executive orders prohibiting discrimination based on the Protected Characteristics in the provision of services. Breach of this covenant may be regarded as a material breach of this Agreement, but nothing in this covenant shall be construed to imply or establish an employment relationship between the State and any applicant or employee of the LPA or any subcontractor.
- B. INDOT is a recipient of federal funds, and therefore, INDOT requires full compliance with all rules, regulations and statutes concerning nondiscrimination requirements and applications. Breach of this section may be regarded as a material breach of this Agreement.

It is the policy of INDOT to assure full compliance with Title VI of the Civil Rights Act of 1964, the Americans with Disabilities Act and Section 504 of the Vocational Rehabilitation Act and all related statutes and regulations in all programs and activities. Title VI and related statutes require that no person in the United States shall on the grounds of race, color or national origin be excluded from participation in, be denied the benefits of, or be subjected to discrimination under any program or activity receiving Federal financial assistance. (INDOT’s nondiscrimination enforcement is broader than the language of Title VI and encompasses other State and Federal protections).

- C. During the performance of this Agreement, the LPA, for itself, its assignees, and successors in interest (hereinafter referred to as the “LPA”) agrees to the following assurances under Title VI of the Civil Rights Act of 1964:
1. **Compliance with Regulations:** The LPA shall comply with the regulations relating to nondiscrimination in Federally assisted programs of the Department of Transportation, Title 49 CFR Part 21, as they may be amended from time to time (hereinafter referred to as the Regulations), which are herein incorporated by reference and made a part of this Agreement.
  2. **Nondiscrimination:** The LPA, with regard to the work performed by it during the Agreement, shall not discriminate on the grounds of race, color, sex, national origin, religion, disability, ancestry, or status as a veteran in the selection and retention of subcontractors, including procurements of materials and leases of equipment. The LPA shall not participate either directly or indirectly in the discrimination prohibited by section 21.5 of the Regulation, including employment practices when the Agreement covers a program set forth in Appendix B of the Regulations.
  3. **Solicitations for Subcontracts, Including Procurements of Materials and Equipment:** In all solicitations either by competitive bidding or negotiation made by the LPA for work to be performed under a subcontract, including procurements of materials or leases of equipment, each potential subcontractor or supplier shall be notified by the LPA of the LPA’s obligations under this Agreement, and the Regulations relative to nondiscrimination on the grounds of race, color, sex, national origin, religion, disability, ancestry, or status as a veteran.
  4. **Information and Reports:** The LPA shall provide all information and reports required by the Regulations, or directives issued pursuant thereto, and shall permit access to its books, records, accounts, other sources of information and its facilities as may be determined by INDOT and the Federal Highway Administration to be pertinent to ascertain compliance with such Regulations, orders, and instructions. Where any information required of the LPA is in the exclusive possession of another who fails or refuses to furnish this information, the LPA shall

certify to INDOT or the Federal Highway Administration as appropriate and shall set forth what efforts it has made to obtain the information.

5. **Sanctions for Noncompliance:** In the event of the LPA's noncompliance with the nondiscrimination provisions of this Agreement, INDOT shall impose such contract sanctions as it or the Federal Highway Administration may determine to be appropriate, including, but not limited to: (a) withholding payments to the LPA under the Agreement until the LPA complies, and/or (b) cancellation, termination or suspension of the Agreement, in whole or in part.
6. **Incorporation of Provisions:** The LPA shall include the provisions of paragraphs 1. through 5. in every subcontract, including procurements of materials and leases of equipment, unless exempt by the Regulations, or directives issued pursuant thereto.

The LPA shall take such action with respect to any subcontract or procurement as INDOT or the Federal Highway Administration may direct as a means of enforcing such provisions including sanctions for non-compliance, provided, however, that in the event the LPA becomes involved in, or is threatened with, litigation with a subcontractor or supplier as a result of such direction, the LPA may request INDOT to enter into such litigation to protect the interests of INDOT, and, in addition, the LPA may request the United States of America to enter into such litigation to protect the interests of the United States of America.

**34. Notice to Parties.** Whenever any notice, statement or other communication is required under this Contract, it shall be sent to the following addresses, unless otherwise specifically advised.

Notices to the State shall be sent to:

**Indiana Department of Transportation – Fort Wayne District**

**ATTN: Jenny Bass, Finance Director**

**Telephone: 260-969-8209**

**Email: [jbass@indot.in.gov](mailto:jbass@indot.in.gov)**

**5333 Hatfield Road, Fort Wayne, IN 46808**

Notices to the LPA shall be sent to:

**City of Goshen, ATTN: Clerk- Treasurer, Richard Aguirre**

**202 S. 5<sup>th</sup> Str., Goshen, IN 46528**

**Telephone: 574-533-8625 – Email: [richardaguirre@goshencity.com](mailto:richardaguirre@goshencity.com)**

As required by IC 4-13-2-14.8, payments to the LPA shall be made via electronic funds transfer in accordance with instructions filed by the LPA with the Indiana Auditor of State.

**35. Order of Precedence; Incorporation by Reference.** [OMITTED – NOT APPLICABLE].

**36. Ownership of Documents and Materials.** [OMITTED – NOT APPLICABLE].

**37. Payments.**

A. All payments shall be made thirty-five (35) days in arrears in conformance with State fiscal policies and procedures and, as required by IC § 4-13-2-14.8, the direct deposit by electronic funds transfer to the financial institution designated by the LPA in writing unless a specific waiver has been obtained from the Indiana Auditor of State. No payments will be made in advance of receipt of the goods or services that are the subject of this Contract except as permitted by IC § 4-13-2-20.

B. If the LPA is being paid in advance for the maintenance of equipment, software or a service as a subscription, then pursuant to IC § 4-13-2-20(b)(14), the LPA agrees that if it fails to fully provide or perform under this Contract, upon receipt of written notice from the State, it shall promptly refund the consideration paid, pro-rated through the date of non-performance.

**38. Penalties/Interest/Attorney's Fees.** The State will in good faith perform its required obligations hereunder and does not agree to pay any penalties, liquidated damages, interest or attorney's fees, except as permitted by Indiana law, in part, IC 5-17-5, IC 34-54-8, and IC 34-13-1.

Notwithstanding the provisions contained in IC 5-17-5, any liability resulting from the State's failure to make prompt payment shall be based solely on the amount of funding originating from the State and shall not be based on funding from federal or other sources.

**39. Progress Reports.** [OMITTED – NOT APPLICABLE].

**40. Public Record.** The LPA acknowledges that the State will not treat this Contract as containing confidential information and the State will post this Contract on the transparency portal as required by Executive Order 05-07 and IC § 5-14-3.5-2. Use by the public of the information contained in this Contract shall not be considered an act of the State.

**41. Renewal Option.** This Contract may be renewed under the same terms and conditions, subject to the approval of the Commissioner of the Department of Administration and the State Budget Director in compliance with IC § 5-22-17-4. The term of the renewed contract may not be longer than the term of the original Contract.

**42. Severability.** The invalidity of any section, subsection, clause or provision of this Contract shall not affect the validity of the remaining sections, subsections, clauses or provisions of this Contract.

**43. Substantial Performance.** This Contract shall be deemed to be substantially performed only when fully performed according to its terms and conditions and any written amendments or supplements.

**44. Taxes.** The State is exempt from most state and local taxes and many federal taxes. The State will not be responsible for any taxes levied on the LPA as a result of this Contract.

**45. Termination for Convenience.** This Contract may be terminated, in whole or in part, by the State, which shall include and is not limited to IDOA and the State Budget Agency whenever, for any reason, the State determines that such termination is in its best interest. Termination of services shall be effected by delivery to the LPA of a Termination Notice at least thirty (30) days prior to the termination effective date, specifying the extent to which performance of services under such termination becomes effective. The LPA shall be compensated for services properly rendered prior to the effective date of termination. The State will not be liable for services performed after the effective date of termination. The LPA shall be compensated for services herein provided but in no case shall total payment made to the LPA exceed the original contract price or shall any price increase be allowed on individual line items if canceled only in part prior to the original termination date. For the purposes of this paragraph, the parties stipulate and agree that IDOA shall be deemed to be a party to this Contract with authority to terminate the same for convenience when such termination is determined by the Commissioner of IDOA to be in the best interests of the State.

**46. Termination for Default.** [OMITTED – NOT APPLICABLE].

**47. Travel.** [OMITTED – NOT APPLICABLE].

**48. Waiver of Rights.** No right conferred on either party under this Contract shall be deemed waived, and no breach of this Contract excused, unless such waiver is in writing and signed by the party claimed to have waived such right. Neither the State's review, approval or acceptance of, nor payment for, the services required under this Contract shall be construed to operate as a waiver of any rights under this Contract or of any cause of action arising out of the performance of this Contract, and the LPA shall be and remain liable to the State in accordance with applicable law for all damages to the State caused by the LPA's negligent performance of any of the services furnished under this Contract.

**49. Work Standards.** The LPA shall execute its responsibilities by following and applying at all times the highest professional and technical guidelines and standards. If the State becomes dissatisfied with the work product of or the working relationship with those individuals assigned to work on this Contract, the State may request in writing the replacement of any or all such individuals, and the LPA shall grant such request.

**50. State Boilerplate Affirmation Clause.** I swear or affirm under the penalties of perjury that I have not altered, modified, changed or deleted the State's standard contract clauses (as contained in the most current *State of Indiana SCM Template*) in any way except for Section 33. Non-Discrimination.

**Non-Collusion and Acceptance**

The undersigned attests, subject to the penalties for perjury, that he/she is the properly authorized representative, agent, member or officer of the LPA, that he/she has not, nor has any other member, employee, representative, agent or officer of the LPA, directly or indirectly, to the best of his/her knowledge, entered into or offered to enter into any combination, collusion or agreement to receive or pay, and that he/she has not received or paid, any sum of money or other consideration for the execution of this Agreement other than that which appears upon the face of this Agreement. **Furthermore, if the undersigned has knowledge that a state officer, employee, or special state appointee, as those terms are defined in IC §4-2-6-1, has a financial interest in the Agreement, the LPA attests to compliance with the disclosure requirements in IC §4-2-6-10.5.**

**Agreement to Use Electronic Signatures**

I agree, and it is my intent, to sign this Agreement by accessing State of Indiana Supplier Portal using the secure password assigned to me and by electronically submitting this Agreement to the State of Indiana. I understand that my signing and submitting this Agreement in this fashion is the legal equivalent of having placed my handwritten signature on the submitted Agreement and this affirmation. I understand and agree that by electronically signing and submitting this Agreement in this fashion I am affirming to the truth of the information contained therein. I understand that this Agreement will not become binding on the State until it has been approved by the Department of Administration, the State Budget Agency, and the Office of the Attorney General, which approvals will be posted on the Active Contracts Database: [https://fs.gmis.in.gov/psp/guest/SUPPLIER/ERP/c/SOI\\_CUSTOM\\_APPS.SOI\\_PUBLIC\\_CNTRCTS.GBL](https://fs.gmis.in.gov/psp/guest/SUPPLIER/ERP/c/SOI_CUSTOM_APPS.SOI_PUBLIC_CNTRCTS.GBL)

**In Witness Whereof**, the LPA and the State have, through duly authorized representatives, entered into this Contract. The parties, having read and understand the foregoing terms of this Contract, do by their respective signatures dated below hereby agree to the terms thereof.

LPA

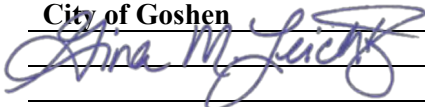
Name of LPA:	<u>City of Goshen</u>
Signature:	<u></u>
Printed Name:	<u>Gina M. Leichty</u>
Title:	<u>Mayor, City of Goshen</u>
Date:	<u>08/28/2029</u>

**STATE OF INDIANA  
Indiana Department of Transportation**

  
District Deputy Commissioner

**Date:** 09/02/2025

**STATE APPROVALS**

*\*All State Approvals are made electronically – see attached confirmation page.\**

**APPROVALS**

**Department of Administration**

\_\_\_\_\_ (for)

Brandon Clifton, Commissioner

**Date:** \_\_\_\_\_

**Budget Agency**

\_\_\_\_\_ (for)

Chad Ranney, State Budget Director

**Date:** \_\_\_\_\_

**APPROVED as to Form and Legality:**

Office of the Attorney General

*Form approval has been granted by the  
Office of the Attorney General pursuant to  
IC 4-13-2-14.3(e) on May 2, 2025.*

**FA 25-22**



Search in Menu



## Document Approval Status

SetID STIND  
Supplier CITY OF GOSHEN

Contract ID 000000000000000000095795

### Review/Edit Approvers

#### Agency Fiscal Approval

STIND/000000000000000000095795: **Approved**

Agency Fiscal Approval

<p><b>Approved</b></p> <p>✓ <a href="#">Michael Hopper-00800</a> Agency Fiscal Approval for SCM 09/23/25 - 9:29 AM</p>	→	<p><b>Approved</b></p> <p>✓ <a href="#">Steven Fanning - 00800</a> Inserted Approver 09/23/25 - 12:24 PM</p>
--	---	--

#### IDOA Approval

STIND/000000000000000000095795: **Approved** [View/Hide Comments](#)

IDOA Legal Approval

<p><b>Approved</b></p> <p>✓ <a href="#">Redding, Sandra-061-Procq</a> IDOA Legal Approval for SCM 10/06/25 - 6:13 PM</p>
--

▶ **Comments**

#### SBA Approval

STIND/000000000000000000095795: **Approved**

SBA Approval

<p><b>Approved</b></p> <p>✓ <a href="#">Gabriel Donnelly- 00057</a> SBA Analyst Approval for SCM 10/07/25 - 2:12 PM</p>
---

[Return to Document Management](#)



**Engineering Department  
CITY OF GOSHEN**

204 East Jefferson Street, Suite I • Goshen, IN 46528-3405

Phone (574) 534-2201 • Fax (574) 533-8626 • TDD (574) 534-3185  
engineering@goshencity.com • www.goshenindiana.org

## MEMORANDUM

TO: Board of Works and Safety and Stormwater Board  
FROM: Department of Environmental Resilience  
RE: **2026 SPRING TREE REMOVAL PROJECT**  
DATE: May 20, 2026

---

Attached please find Change Order No. 1 – A Balancing Change Order.

Change Order No. 1 increases the contract price by \$822.72, making the final contract amount \$105,365.97. This amount is 0.79% over the original bid amount of \$104,543.25.

<b>Original contract amount</b>	<b>\$104,543.25</b>
<b>Change Order No. 1</b>	<b>\$ 822.72</b>
<hr/>	
<b>Revised contract amount</b>	<b>\$105,365.97</b>

**Suggested Motion: Move to approve the balancing Change Order No. 1 increasing the contract by \$822.72, for a final contract amount of \$105,365.97.**

**CHANGE ORDER FORM**

Pg 1 of 3

Change Order No. 1

Date: 5/4/2026

**CITY OF GOSHEN, INDIANA**  
**Department of Environmental Resilience**  
**410 W. Plymouth Ave.**  
**Goshen, IN 46526**

OWNER: City of Goshen  
PROJECT NAME: 2026 Tree Removal Project  
PROJECT NUMBER:  
CONTRACTOR: Cut Rite Services

I. DESCRIPTION OF WORK INVOLVED (Use additional sheets if needed)

Line item adjustments to serve as a balancing change order to close the project.

7	Tree Removal & Clearing - Ranges 20-24" (Note: This balances the line item out)	2.0 EA	@ \$1,147.74	-----	\$2,295.48
8	Tree Removal & Clearing Ranges 25-29" (Note: This balances the line item out)	-1.0 EA	@ \$1,460.76	-----	-\$1,460.76
CO 1.1	Stump Removal (Note: This balances the line item out)	1 EA	@ \$450.00	-----	\$450.00
CO 1.2	Sidewalk Repair (Note: This balances the line item out)	-7.70 SYDS	@ \$60.00	-----	-\$462.00
			This Page	=	\$822.72

CHANGE ORDER FORM

II. ADJUSTMENTS IN AMOUNT OF CONTRACT

1. Amount of original contract		\$104,543.25
2. Net ( <del>Addition/Reduction</del> ) due to all Previous Contract Supplements Numbers	1 to <u>1</u>	
3. Amount of Contract, not including this supplement		\$104,543.25
4. Addition/ <del>Reduction</del> to Contract due to this supplement		\$822.72
5. Amount of Contract, including this supplemental		\$105,365.97
6. Total ( <del>Addition/Reduction</del> ) due to all Change Orders (Line 2 + Line 4)		\$822.72
7. Total percent of change in the original contract price Includes Change Order No.	4 to <u>1</u>	0.79%
(Line 6 divided by Line 1)		

III. CONTRACT SUPPLEMENT CONDITIONS

1. The contract completion date established in the original contract or as modified by previous Contract Supplement(s) is hereby ~~extended/reduced~~ by 0 calendar days, making the final completion date N/A.

2. Any additional work to be performed under this Contract supplement will be carried out in compliance with the specifications included in the preceding Description of Work Involved, with the supplemental contract drawing designed as \_\_\_\_\_, and under the provisions of the original contract including compliance with applicable equipment specifications, general specifications and project specifications for the same type of work.

3. This Contract Supplement, unless otherwise provided herein, does not relieve the contractor from strict compliance with the guarantee provisions of the original contract, particularly those pertaining to performance and operation of equipment.

4. The contractor expressly agrees that he will place under coverage of his Performance and Payment Bonds and contractor's insurance, all work covered by this Contract Supplement. The contractor will furnished to the owner evidence of increased coverage of this Performance and Payments bonds for the accrued value of all contract supplements, which exceed the original contract price by twenty (20) percent.

**CHANGE ORDER FORM**

Pg. 5 of 5

Change Order No. 1  
Date: 5/4/2026

**RECOMMENDED FOR ACCEPTANCE**



\_\_\_\_\_  
Aaron Sawatsky-Kingsley

**ACCEPTED:** BOARD OF PUBLIC WORKS  
CITY OF GOSHEN, INDIANA

\_\_\_\_\_  
Mayor

\_\_\_\_\_  
Member

\_\_\_\_\_  
Member

\_\_\_\_\_  
Member

\_\_\_\_\_  
Member

\_\_\_\_\_  
Member

**ACCEPTED:** CONTRACTOR

\_\_\_\_\_  
Cut Rite Services

**BY:** \_\_\_\_\_  
Signature of authorized representative

\_\_\_\_\_  
Printed

\_\_\_\_\_  
Title



**Engineering Department  
CITY OF GOSHEN**

204 East Jefferson Street, Suite 1 • Goshen, IN 46528-3405

Phone (574) 534-2201 • Fax (574) 533-8626 • TDD (574) 534-3185  
engineering@goshencity.com • www.goshenindiana.org

## MEMORANDUM

TO: Board of Public Works and Safety

FROM: Goshen Engineering Department

RE: **CHICAGO AVENUE ROAD CLOSURE (JN: 2024-0029)**

DATE: June 4, 2026

---

Niblock Excavating has requested permission to close Chicago Avenue, from Pike Street/US Highway 33 to Indiana Avenue, from Monday, June 8, 2026, until Thursday, July 2, 2026. The road will be closed for Niblock to replace galvanized water services as part of the City's North Goshen Service Line Replacement and Utility Improvements project. The road will be closed to thru traffic, with a rolling full closure, as work progresses from Pike Street to Indiana Avenue. All appropriate traffic control devices will be utilized.

**Requested Motion: Move to approve the closure of Chicago Avenue, from Pike Street to Indiana Avenue, from June 8, 2026, until July 2, 2026.**

**APPROVED:  
BOARD OF PUBLIC WORKS & SAFETY  
CITY OF GOSHEN, INDIANA**

\_\_\_\_\_  
Gina Leichty, Mayor

\_\_\_\_\_  
Barb Swartley, Member

\_\_\_\_\_  
Mary Nichols, Member

\_\_\_\_\_  
Orv Myers, Member

\_\_\_\_\_  
Michael Landis, Member



**Chicago Avenue - Road Closure**

Estimated Phase Starting Dates:

Phase 1A: Monday, June 8, 2026  
 Phase 1B: Tuesday, June 9, 2026  
 Phase 2: Monday, June 15, 2026

(Full closure of Phase 1A shown below)

**Chicago Avenue Closure**  
 North Goshen Service Line Replacement Project (2024-0029)

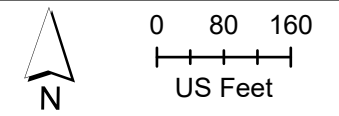

The City of Goshen's Digital Data is the property of the City of Goshen and Elkhart County, Indiana. All graphic data supplied by the city and county has been derived from public records that are constantly undergoing change and is not warranted for content or accuracy. The city and county do not guarantee the positional or thematic accuracy of the data. The cartographic digital files are not a legal representation of any of the features depicted, and the city and county disclaim any assumption of the legal status they represent. Any implied warranties, including warranties of merchantability or fitness for a particular purpose, shall be expressly excluded. The data represents an actual reproduction of data contained in the city's or county's computer files. This data may be incomplete or inaccurate, and is subject to modifications and changes. City of Goshen and Elkhart County cannot be held liable for errors or omissions in the data. The recipient's use and reliance upon such data is at the recipient's risk. By using this data, the recipient agrees to protect, hold harmless and indemnify the City of Goshen and Elkhart County and its employees and officers. This indemnity covers reasonable attorney fees and all court costs associated with the defense of the city and county arising out of this disclaimer.

**The City of Goshen**  
 Department of Public Works &  
 Safety Office of Engineering  
 204 East Jefferson Street, Goshen, Indiana 46528  
 Phone: 574-534-2201 Fax: 574-533-8626

Created: 6/2/2026  
 by Andrew Land, Project Manager